



Kraus & Naimer

BLUE LINE switchgear

since 1907

Catalog 100

04/2010

Control and Load Switches for higher Capacities

CL type up to 20 A

CAD, CA and C type up to 315 A

L type up to 2400 A

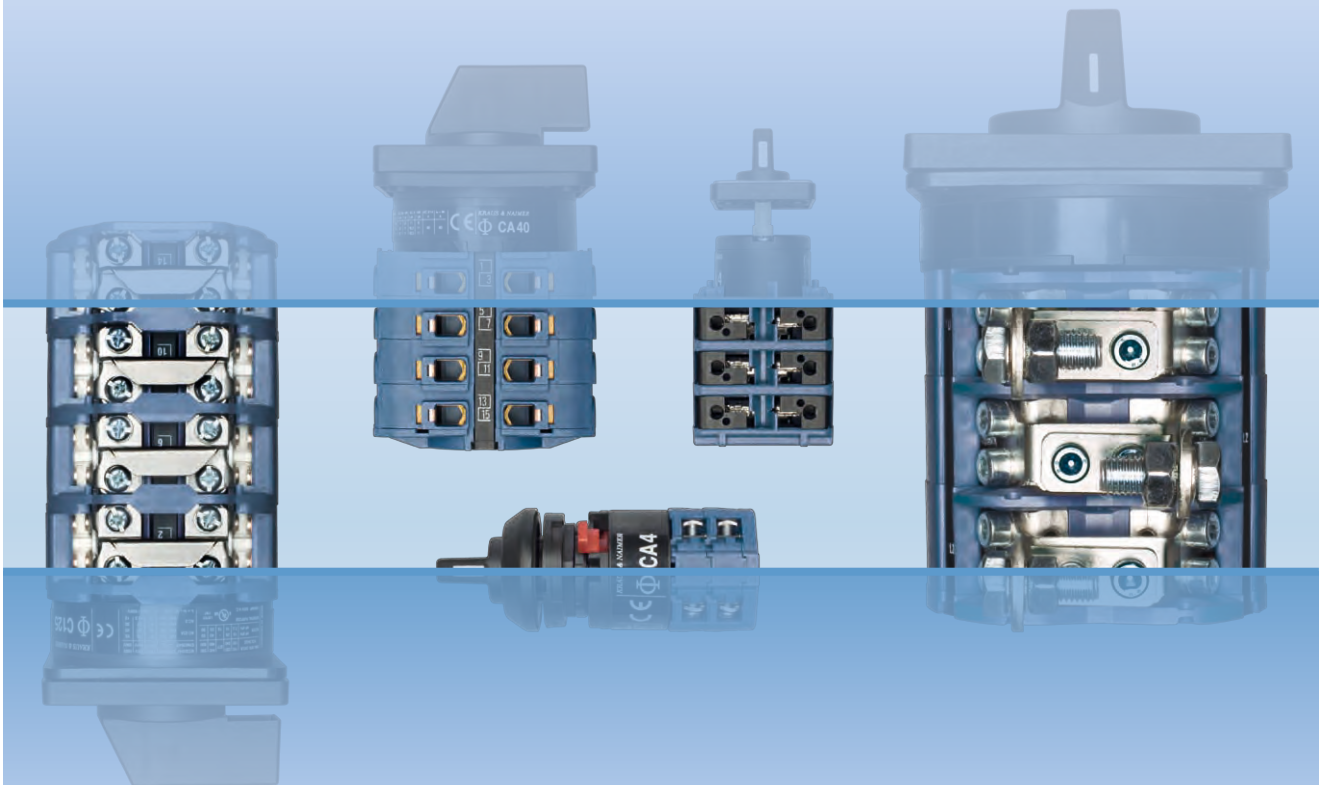

Kraus & Naimer

The development of the Blue Line rotary switch, contactor and motor starter product ranges is based on more than hundred years experience by Kraus & Naimer in the design and manufacture of electrical switchgear. Kraus & Naimer pioneered the introduction of the cam operated rotary switch and continues to be recognized as the world leader in that product field.

BLUE LINE

Blue Line products are protected by numerous patents throughout the industrial world. They are built to national and international standards and designed to withstand adverse temperatures and climates.

Blue Line products are accepted and universally recognized for their quality and workmanship. They are supported by a worldwide sales and service organization.

The Kraus & Naimer Registered Trademark



WORLDWIDE SYMBOL
FOR QUALITY SWITCHGEAR

Disconnectors and Main Switches acc. to IEC 60947-3 see Catalog 500

Contents	Page
Construction Data	2
Dimensions and Nominal Ratings	3
How to order	4, 5
Switch Function and Configuration	
CL Switches 10 A-20 A	
C, CA and CAD Switches 10 A-315 A	
ON/OFF Switches	6, 7
Double-throw Switches	8-10
General Application Switches	10
Coding Switches	11
Multi-step Switches	12-14
Voltmeter Switches	15-17
Ammeter Switches	17-19
Volt-ammeter Switches	19
Control Switches	19, 20
Motor Switches	21-23
L Switches 350 A-2400 A	
ON/OFF Switches	24-26
Double-throw Switches	26, 27
Multi-step Switches	27, 28
Types of Mounting	
Panel Mounting	29-33
Base Mounting	34
Wall Mounting	35
Escutcheon Plates	36, 37
Handles	38
International Standards and Approvals	39
Technical Data	40-43
Dimensions	
Panel Mounting	44-48
Base Mounting	48, 49
Wall Mounting	50
Overall Switch Lengths	50, 51
Blue Line Switchgear: Summary	52

Construction Data

The load switches of the C, CA, CAD and CL-series offer a solution for most cam switch applications. Different contact designs, contact materials and terminals allow for their use as control switches, instrumentation switches and motor control switches, as well as in electronic circuitry and in aggressive environments according to IEC 60947-3 and VDE 0660 part 107.

The stage is the basis for all switches and can be supplied with a maximum of 2 contacts. The terminals are accessible from the side. CA and CAD switches are supplied with open terminals to facilitate wiring and are protected against accidental finger contact according to EN 50274, VDE 0660 part 514 and BGV A3. Switches up to type CA25B are supplied with captive screws with clamping plates. The switch types CA40-CA63 are supplied with box terminals. Captive plus-minus terminal screws and integrated screwdriver guides facilitate wiring.

The switches of the new CL-series are supplied with rust-free and acid-resisting IDC terminals (Insulation Displacement Connection) instead of screw type terminals. The stripping or preparation of the insulation is no longer required. Eliminate errors due to i.e., stripped end of the conductor too long or too short, incorrect sleeves used, sleeves crimped incorrectly or wrong crimping tool is used, terminal screws not tightened properly etc. The CL switches reduce installation time by 60 %-70 % compared to the screw type terminals. This translates to significant cost savings. For connecting 2 conductors to a terminal an additional screw terminal with plus-minus screw is available.

If a positive manual operation or a higher DC rating is required, many of these switches can be fitted with a snap action latching mechanism - suffix „S“ - to the switch type.

The cam-operated switches of the L-series are continuous current rated for off-load switching. They may be used to switch resistive or low inductive loads.

Special Contact Systems

CA4/CA4-1

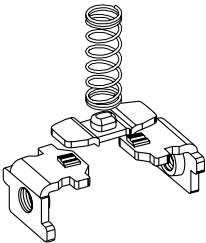

High contact reliability by multiple cross-point contacts, electronic compatible, CA4 with 1 μ and CA4-1 with 35 μ gold plating.

CAD4-1/CAD11/CAD12

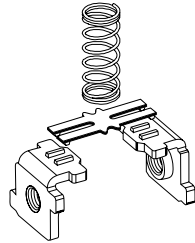

High contact reliability by H-bridge design with "cross-wire" contacts. The contact system with gold-plated contacts (CAD12 with silver contact) allows for low voltages, electronic compatible.

CL Switches



CA and CAD Switches (CA4-CA25B)



CA Switches (CA40-CA63)



C Switches



L Switches



Above illustrates the standard terminal positions.

Type	Size	Possible Switching Angles	Max. No. of Stages
CA4, CA4-1, CAD4-1	S00	30°, 45°, 60°, 90°	9
CL4	S00	30°, 45°, 60°, 90°	8
CA10-CA25	S0	30°, 45°, 60°, 90°	12
CA10S-CA25S	S0	60°	on request
CAD11, CAD12	S0	30°, 45°, 60°, 90°	12
CL10	S0	30°, 45°, 60°, 90°	10
CA10B-CA25B	S1	30°, 45°, 60°, 90°	12
CA40, CA50, CA63	S1	30°, 45°, 60°, 90°	12
C80, C125, C200-4	S2	20°, 30°, 45°, 60°, 90°	12
C315	S3	20°, 30°, 45°, 60°, 90°	12
L350/51, L630/31, L1000/01, L1250/51	S2	30°, 45°, 60°, 90°	12
L400, L600, L800, L1200, L1600, L2000	S3	30°, 45°, 60°, 90°	12

Nominal Ratings

Switch Size	Type	According to IEC 60947-3/VDE 0660 part 107			
		Insulation Voltage ¹ U _i V	Thermal Current I _u /I _{th} A	Motor Rating 3 x 380 V-440 V AC-23 AC-3 kW kW	
S00 	CA4	440	10	3	2,2
	CA4-1	440	10	3	2,2
	CAD4-1	440	5	-	-
	CL4	440	10	3	2,2
S0 	CA10	690	20	7,5	5,5
	CA11	690	20	7,5	5,5
	CA20	690	25	11	7,5
	CA25	690	32	15	11
	CAD11	600	6	-	-
	CAD12	600	6	-	-
	CL10	690	20	7,5	5,5
S1 	CA10B	690			
	CA11B	690	20	7,5	5,5
	CA20B	690	20	7,5	5,5
	CA25B	690	25	11	7,5
	CA40	690	32	15	11
	CA50	690	40	18,5	15
	CA63	690	50	22	18,5
				63	30
S2 	C80	690	115	45	30
	C125	690	150	75	37
	C200-4	690	200	75	37
	L350	690	350	90	37
	L351	690	350	90	37
	L630	690	630 ²	90	37
	L631	690	630 ²	90	37
	L1000	690	1000 ²	90	37
	L1001	690	1000 ²	90	37
	L1250	690	1250 ²	90	37
	L1251	690	1250 ²	90	37
S3 	C315	690	315	132	55
	C316³	1000	315	132	55
	L400	690	500	132	55
	L600	690	800 ²	132	55
	L800	690	1100 ²	132	55
	L1200	690	1450 ²	132	55
	L1600	690	1900 ²	132	55
	L2000	690	2400 ²	132	55

For further technical details, refer to pages 40-43.
To furnish with gold contacts and quick connects see page 4.

¹Valid for lines with grounded common neutral termination, overvoltage category III, pollution degree 3. Values for other supply systems on request. ²Ambient temperature 35 °C max. ³Additional switch functions on request.

How to order

Disconnectors and Main Switches according to IEC 60947-3 see Catalog 500

Three types of data (shown below) are required for ordering Blue Line cam-operated switches. Code numbers for ordering are shown in this catalog.

1. Type of Switch

The type of switch required may be easily selected by referring to the table on page 3 which shows the thermal current, power rating and dimensions of each switch. For further technical details, refer to pages 40-43. Variations of contacts and terminals are shown below.

2. Switch Function

The code numbers for standard switches shown on pages 6-28 indicate the switch function, escutcheon plate, handle and any optional extras.

Additional coding to modify type and color of handle and escutcheon plate is explained below.

3. Type of Mounting

Types of mounting are shown on pages 29-35. Catalog **101** describes enclosures and optional extras.

Specify the mounting code to indicate required mounting.

CA10

A202-600

VE

Type of Switch

Extending the switch type coding the following combinations will define:

Amendment	Definition	For switch types
-1	with gold contacts ¹	CA10, CA11, CA10B, CA11B
-4	with quick connects	CA4
B	S0 switches with latching mechanism size S1	CAD11, CAD12
C	S1 switches with latching mechanism size S2	CA40, CA50, CA63
L	with lockout-relay w/o manual release for std. sw.	CA10, CA40 ² , CA50 ² , CA63 ²
M	with lockout-relay with manual release for std. sw.	CA10, CA40 ² , CA50 ² , CA63 ²
X	with power failure release	CA10, CA11, CA20, CA25, CAD12, CA40 ² , CA50 ² , CA63 ²
Y	with power failure release and trip-free release	CA10, CA11, CA20
S	with snap action	CA10, CA11, CA20, CA25, CA40, CA50, CA63
R	with spring return latching mechanism	with 60° or 90° switching CA10

Example: Coding for switch type **CA10** with gold contacts is **CA10-1**.

Modification of Switches

The part number for switch function and options may be modified in cases where items are required other than standard. The modification may involve the escutcheon plate inscription, color combination of escutcheon plate and handle, type of escutcheon plate and handle or the optional extra.

Switch Size	Escutcheon Plate Frame	Handle	Escutcheon Plate Backing	Escutcheon Plate Lettering	Dash Number
S0, S1, S2, S3	electro-gray	electro-gray	brushed alu	black	-100
S0, S1, S2, S3	electro-gray	electro-gray	black	mat silver	-500
S00, S0, S1, S2, S3	black	black	brushed alu	black	-600
S00, S0, S1, S2, S3	black	black	black	mat silver	-700

Function	Escutch. Plate	Type/Handle				Code	Stages	Connection Diagram
		CA4 CA4-1 CAD4-1 CL4	CAD.. CA10- CA25 CL10	CA10B- CA25B	CA40- C315			

ON/OFF Switches with 60° Switching

1 pole						A200-600	1	
2 pole						A201-600	1	
3 pole						A202-600	2	
3 pole with red handle						A202-626	2	
3 pole with V850 padlock attachment						A202-627	2	
4 pole						A203-600	2	
4 pole 1 pole preclose 6° ¹						A653-600	2	
5 pole						A341-600	3	
6 pole						A342-600	3	
7 pole						A343-600	4	
8 pole						A344-600	4	
8 pole 2 pole preclose 6° ¹						A654-600	4	
9 pole					A345-600	5		
10 pole					A346-600	5		
11 pole					A347-600	6		
12 pole					A348-600	6		
1 pole						A200-620	1	
2 pole						A201-620	1	
3 pole						A202-620	2	
4 pole						A203-620	2	
4 pole 1 pole preclose 6° ¹						A653-620	2	
5 pole						A341-620	3	
6 pole						A342-620	3	
7 pole						A343-620	4	
8 pole						A344-620	4	
8 pole 2 pole preclose 6° ¹						A654-620	4	
9 pole						A345-620	5	
10 pole						A346-620	5	
11 pole					A347-620	6		
12 pole					A348-620	6		
1 pole						A200-621	1	
2 pole						A201-621	1	
3 pole						A202-621	2	
4 pole						A203-621	2	
4 pole 1 pole preclose 6° ¹						A653-621	2	
5 pole						A341-621	3	
6 pole					A342-621	3		
1 pole						A200-622	1	
2 pole						A201-622	1	
3 pole						A202-622	2	
4 pole						A203-622	2	
4 pole 1 pole preclose 6° ¹						A653-622	2	
5 pole						A341-622	3	
6 pole					A342-622	3		
1 pole						A200-623	1	
2 pole						A201-623	1	
3 pole						A202-623	2	
4 pole						A203-623	2	
4 pole 1 pole preclose 6° ¹						A653-623	2	
5 pole						A341-623	3	
6 pole					A342-623	3		
1 pole						A200-624	1	
2 pole						A201-624	1	
3 pole						A202-624	2	
4 pole						A203-624	2	
4 pole 1 pole preclose 6° ¹						A653-624	2	
5 pole						A341-624	3	
6 pole					A342-624	3		
1 pole						A200-625	1	
2 pole						A201-625	1	
3 pole						A202-625	2	
4 pole						A203-625	2	
4 pole 1 pole preclose 6° ¹						A653-625	2	
5 pole						A341-625	3	
6 pole					A342-625	3		

¹for use in a three phase four-wire system with switched neutral

Switch Function and Configuration

C, CA, CAD, CL Switches

Function	Escutch. Plate	Type/Handle				Code	Stages	Connection Diagram
		CA4 CA4-1 CAD4-1 CL4	CAD.. CA10- CA25 CL10	CA10B- CA25B	CA40- C315			

ON/OFF Switches with 90° Switching

1 pole contacts							A290-600	1	 1, 2, 3, 4, 5 and 6 pole
2 pole preclose 30°							A291-600	1	
3 pole							A292-600	2	
4 pole							A324-600	2	
4 pole 1 pole preclose 60° ¹							A293-600	2	
4 pole 3 pole preclose 30°							A327-600	2	
5 pole contacts							A290-620	1	 4 pole 1 pole preclose 60°
2 pole preclose 30°							A291-620	1	
3 pole							A292-620	2	
4 pole							A324-620	2	
4 pole 1 pole preclose 60° ¹							A293-620	2	
4 pole 3 pole preclose 30°							A327-620	2	
5 pole contacts							A325-620	3	 4 pole 3 pole preclose 30°
6 pole preclose 30°							A326-620	3	
3 pole 360° rotation							A208-600	2	
							A208-620	2	
3 pole for foot operation							A386-600	2	
							CA40-CA63		

ON/OFF Switches with 30° Switching

1 pole							A100-600	1	 1-4 pole
2 pole							A101-600	1	
3 pole							A102-600	2	
4 pole							A103-600	2	
1 pole with spring return							A204-600	1	 1-4 pole
2 pole with spring return							A205-600	1	
3 pole with spring return							A206-600	2	
4 pole with spring return							A207-600	2	
1 pole with spring return							A204-620	1	 1-4 pole
2 pole with spring return							A205-620	1	
3 pole with spring return							A206-620	2	
4 pole with spring return							A207-620	2	

¹for use in a three phase four-wire system with switched neutral ²not available for switch type CA25 ³not available for switch type C315

Function	Escutch. Plate	Type/Handle				Code	Stages	Connection Diagram
		CA4 CA4-1 CAD4-1 CL4	CAD.. CA10- CA25 CL10	CA10B- CA25B	CA40- C315			

Double-throw Switches without „OFF“ 60° Switching

1 pole						A220-600	1	
2 pole						A221-600	2	
3 pole						A222-600	3	
4 pole						A223-600	4	
4 pole 1 pole preclose 6° ³						A673-600	4	
5 pole						A369-600	5	
6 pole						A370-600	6	
7 pole						A371-600	7	
8 pole						A372-600	8	
8 pole 2 pole preclose 6° ³						A972-600	8	
9 pole						A373-600	9	
10 pole						A374-600	10	
11 pole					A375-600	11		
12 pole					A376-600	12		

Double-throw Switches without „OFF“ with electrically isolated contacts

1 pole						A720-600	1	
2 pole						A721-600	2	
3 pole						A722-600	3	
4 pole						A723-600	4	
4 pole 1 pole preclose 6° ³						A973-600	4	
1 pole with spring return						A795-600	1	

Double-throw Switches without „OFF“ 30° Switching

1 pole						A120-600	1	
2 pole						A121-600	2	
3 pole						A122-600	3	
4 pole						A123-600	4	
1 pole with spring return						A295-600	1	
2 pole with spring return						A296-600	2	
3 pole with spring return						A297-600	3	
1 pole with spring return						A295-620	1	
2 pole with spring return						A296-620	2	
3 pole with spring return						A297-620	3	

¹not available for switch type CA25 ²not available for switch type CL4 ³for use in a three phase four-wire system with switched neutral
⁴not available for switch type CL10

Switch Function and Configuration

C, CA, CAD, CL Switches

Function	Escutch. Plate	Type/Handle				Code	Stages	Connection Diagram
		CA4 CA4-1 CAD4-1 CL4	CAD.. CA10- CA25 CL10	CA10B- CA63	C80- C315			

Double-throw Switches with Center „OFF“ 60° Switching

1 pole 2 pole 3 pole 4 pole 4 pole 1 pole preclose 6° ³ 5 pole 6 pole 7 pole 8 pole 8 pole 2 pole preclose 6° ³						A210-600 A211-600 A212-600 A213-600 A913-600 A361-600 A362-600 A363-600 A364-600 A664-600	1 2 3 4 4 5 6 7 8 8	 1-4 pole 4 pole 1 pole preclose 6° 5 pole 6 and 7 pole 8 pole 8 pole 2 pole preclose 6°
1 pole 2 pole 3 pole 4 pole 4 pole 1 pole preclose 6° ³ 5 pole 6 pole 7 pole 8 pole 8 pole 2 pole preclose 6° ³						A210-620 A211-620 A212-620 A213-620 A913-620 A361-620 A362-620 A363-620 A364-620 A664-620	1 2 3 4 4 5 6 7 8 8	
1 pole 2 pole 3 pole						A210-621 A211-621 A212-621	1 2 3	
1 pole 2 pole 3 pole						A210-622 A211-622 A212-622	1 2 3	
1 pole 2 pole 3 pole						A210-623 A211-623 A212-623	1 2 3	
1 pole 2 pole 3 pole 4 pole 4 pole 1 pole preclose 6° ³						A210-624 A211-624 A212-624 A213-624 A913-624	1 2 3 4 4	

Double-throw Switches with Center „OFF“ 90° Switching

1 pole 2 pole 3 pole 4 pole 1 pole preclose 60°						A218-600 A219-600 A299-600 A294-600	1 2 3 4	 1-4 pole
1 pole 2 pole 3 pole 4 pole 1 pole preclose 60°						A218-620 A219-620 A299-620 A294-620	1 2 3 4	

Double-throw Switches with Center „OFF“ and electrically isolated contacts

1 pole 2 pole 3 pole 4 pole 4 pole 1 pole preclose 6° ³						A710-600 A711-600 A712-600 A713-600 A963-600	1 2 3 4 4	 1-4 pole 4 pole 1 pole preclose 6°
1 pole with spring return 2 pole to center						A714-600 A715-600	1 2	 1 and 2 pole

¹switch type C315 with handle ²not available for switch type C315 ³for use in a three phase four-wire system with switched neutral

Function	Escutch. Plate	Type/Handle	Code	Stages	Connection Diagram
		CA4 CAD.. CA4-1 CA10- CA10B- CA40- CAD4-1 CA25 CA25B C315 CL4 CL10			

Double-throw Switches with Spring Return to Center

1 pole with spring return to center						A214-600 A215-600 A216-600	1 2 3	<p>1-3 pole</p>
2 pole with spring return to center						A214-620 A215-620 A216-620	1 2 3	
3 pole with spring return to center						A214-600 A215-600 A216-600	1 2 3	
1 pole with spring return from left to center						A320-600 A321-600 A322-600	1 2 3	<p>1-3 pole</p>
2 pole with spring return from left to center						A320-621 A321-621 A322-621	1 2 3	
3 pole with spring return from left to center						A320-600 A321-600 A322-600	1 2 3	

General Application Switches

1 pole 2 Gang						A310-600 A312-600 A314-600	1 2 3	<p>1 pole</p>	
2 pole Switching sequence: 0, A, A+B									<p>2 pole</p>
3 pole									
1 pole						A310-620 A312-620 A314-620	1 2 3	<p>1 pole</p>	
2 pole									<p>2 pole</p>
3 pole									
1 pole 3 Gang						A311-600 A313-600 A315-600	2 3 5	<p>1 pole</p>	
2 pole Switching sequence: 0, A, A+B, A+B+C									<p>2 pole</p>
3 pole									
1 pole						A311-620 A313-620 A315-620	2 3 5	<p>1 pole</p>	
2 pole									<p>2 pole</p>
3 pole									
1 pole 2 Gang						A330-600 A331-600 A332-600	1 2 3	<p>1 pole</p>	
2 pole Series switching									<p>2 pole</p>
3 pole Switching sequence: 0, A, B, A+B									
1 pole						A330-620 A331-620 A332-620	1 2 3	<p>1 pole</p>	
2 pole									<p>2 pole</p>
3 pole									
2 pole 2 Gang						A339-600	2		
Series-parallel Switching									
Switching sequence: 0, A+B series, A, A+B parallel						A339-620	2		

¹not available for switch type CA25 ²not available for switch type C315 ³available only up to switch type CA63

Switch Function and Configuration

C, CA, CAD, CL Switches

Function	Escutch. Plate	Type/Handle				Code	Stages	Connection Diagram
		CA4 CA4-1 CAD4-1 CL4	CA10 CAD11 CAD12 CL10	CA10B- CA25B	CA40- C315			

Coding Switches/Binary Code

0 - 7 360° rotation					A540-600	2	
0 - 7 complement 360° rotation					A541-600	2	
0 - 7 + complement 360° rotation					A542-600	3	
0 - 9					A550-600	2	
0 - 9 complement					A551-600	2	
0 - 9 + complement					A552-600	4	
0 - 11 360° rotation					A543-600	2	
0 - 11 + complement 360° rotation					A545-600	4	

Function	Escutch. Plate	Type/Handle	Code	Stages	Connection Diagram
		CA4 CAD.. CA4-1 CA10- CA10B- C80- CAD4-1 CA25 CA63 C315 CL4 CL10			

Multi-step Switches without „OFF“

1 pole 3 Step 2 pole 3 pole 4 pole 5 pole 6 pole						A230-600 A250-600 A270-600 A476-600 A484-600 A489-600	2 3 5 6 8 9	
1 pole 4 Step 2 pole 3 pole 4 pole 5 pole 6 pole						A231-600 A251-600 A271-600 A477-600 A485-600 A490-600	2 4 6 8 10 12	
1 pole 5 Step 2 pole 3 pole 4 pole						A232-600 A252-600 A272-600 A478-600	3 5 8 10	
1 pole 6 Step 2 pole 3 pole						A233-600 A253-600 A273-600	3 6 9	
1 pole 7 Step 2 pole 3 pole						A234-600 A254-600 A274-600	4 7 11	
1 pole 8 Step 2 pole 3 pole						A235-600 A255-600 A275-600	4 8 12	
1 pole 9 Step						A236-600	5	
1 pole 10 Step						A237-600	5	
1 pole 11 Step						A238-600	6	
1 pole 12 Step 1 pole 360° rotation						A239-600 A639-600	6 6	

1switch type C315 with handle 2not available for switch type CL4 3not available for switch type CA11B 4not available for switch type CL10

Switch Function and Configuration

C, CA, CAD, CL Switches

Function	Escutch. Plate	Type/Handle				Code	Stages	Connection Diagram
		CA4 CA4-1 CAD4-1 CL4	CAD.. CA10- CA25 CL10	CA10B- CA63	C80- C315			

Multi-step Switches without „OFF“ with electrically isolated contacts

1 pole 3 Step						A730-600	2	 1 pole
2 pole						A750-600	3	 2 pole
1 pole 4 Step						A731-600	2	 1 pole
2 pole						A751-600	4	 2 pole

Multi-step Switches with „OFF“

1 pole 2 Step						A240-600	1	 1-6 pole
2 pole						A260-600	2	
3 pole						A280-600	3	
4 pole						A480-600	4	
5 pole						A486-600	5	
6 pole						A491-600	6	
1 pole						A240-620	1	1-6 pole
2 pole						A260-620	2	
3 pole						A280-620	3	
4 pole						A480-620	4	
5 pole						A486-620	5	
6 pole						A491-620	6	
1 pole 3 Step						A241-600	2	 1 and 2 pole
2 pole						A261-600	3	
3 pole						A281-600	5	
4 pole						A481-600	6	
5 pole						A487-600	8	
1 pole						A241-620	2	3 pole
2 pole						A261-620	3	
3 pole						A281-620	5	
4 pole						A481-620	6	
5 pole						A487-620	8	
1 pole						A241-621	2	4 pole
2 pole						A261-621	3	
								 5 pole

Function	Escutch. Plate	Type/Handle				Code	Stages	Connection Diagram
		CA4 CA4-1 CAD4-1 CL4	CAD.. CA10- CA25 CL10	CA10B- CA63	C80- C315			

Multi-step Switches with „OFF“

1 pole 4 Step 2 pole 3 pole 4 pole						A242-600 A262-600 A282-600 A482-600	2 4 6 8	
1 pole 4 Step 2 pole 3 pole 4 pole						A242-620 A262-620 A282-620 A482-620	2 4 6 8	1-4 pole
1 pole 5 Step 2 pole 3 pole						A243-600 A263-600 A283-600	3 5 8	
1 pole 5 Step 2 pole 3 pole						A243-620 A263-620 A283-620	3 5 8	1-3 pole
1 pole 6 Step 2 pole 3 pole						A244-600 A264-600 A284-600	3 6 9	
1 pole 6 Step 2 pole 3 pole						A244-620 A264-620 A284-620	3 6 9	1-3 pole
1 pole 7 Step 2 pole						A245-600 A265-600	4 7	
1 pole 7 Step 2 pole						A245-620 A265-620	4 7	1 pole 2 pole
1 pole 8 Step						A246-600	4	
1 pole 8 Step						A246-620	4	
1 pole 9 Step						A247-600	5	
1 pole 9 Step						A247-620	5	
1 pole 10 Step						A248-600	5	
1 pole 10 Step						A248-620	5	
1 pole 11 Step 1 pole 360° rotation						A249-600 A649-600	6 6	
1 pole 11 Step 1 pole 360° rotation						A249-620 A649-620	6 6	

¹not available for switch type CL4

Switch Function and Configuration

C, CA, CAD, CL Switches

Function	Escutch. Plate	Type/Handle	Code	Stages	Connection Diagram
	CA4 CA4-1 CAD4-1 CL4	CA10- CA25	CAD.. CL10	CA10B- CA25B	

Voltmeter Switches without „OFF“

3 phase 3 wire						A023-600	2	
						A023-620	2	
3 phase 3 wire 3 phase to phase and phase to neutral						A025-600	3	
						A025-620	3	

Voltmeter Switches with „OFF“

2 pole 360° rotation						A002-600	1	
3 phase 3 wire						A004-600	2	
						A004-620	2	
						A004-621	2	
						A004-622	2	
						A004-623	2	
						A004-624	2	
						A011-600	2	

Function	Escutch. Plate	Type/Handle	Code	Stages	Connection Diagram	
		CA4 CA4-1 CAD4-1 CL4	CA10- CA25	CAD.. CL10	CA10B- CA25B	

Voltmeter Switches with „OFF“

3 phase to neutral						A005-600	2	
						A005-620	2	
						A005-621	2	
						A005-622	2	
						A005-623	2	
3 phase to phase and 3 phase to neutral						A007-600	3	
						A007-620	3	
						A007-621	3	
						A007-622	3	
						A007-623	3	
2 separate 3 phase with center „OFF“						A008-600	4	
						A008-620	4	
						A008-621	4	
						A008-622	4	

Switch Function and Configuration

C, CA, CAD, CL Switches

Function	Escutch. Plate	Type/Handle	Code	Stages	Connection Diagram
	CA4 CA4-1 CAD4-1 CL4	CAD.. CA10- CA25 CL10	CA10B- CA50	CA63- C125	

Voltmeter Switches with „OFF“

3 phase and 1 phase to neutral					A010-600	3	
					A010-620	3	
					A010-621	3	
					A010-622	3	

Ammeter Switches

Single pole with one current transformer					A046-600	1	
					A046-620	1	
					A046-621	1	
Single pole with 3 current transformers without „OFF“					A017-600	3	
					A017-620	3	
		CL4	CL10		A059-600		
		CL4	CL10		A059-620		
Single pole with 3 current transformers with „OFF“ 360° rotation					A048-600	3	
					A048-620	3	
					A048-621	3	
		CL4	CA10 CL10		A058-621		
					A048-622	3	
		CL4	CL10		A058-622		
					A048-623	3	
	CL4	CL10		A058-623			

¹available only up to switch type CA25B ²not available for switch types CL4 and CL10

Function	Escutch. Plate	Type/Handle	Code	Stages	Connection Diagram	
		CA4 CA4-1 CAD4-1 CL4	CAD.. CA10- CA25 CL10	CA10B- CA50	CA63- C125	

Ammeter Switches

Single pole with 2 current transformers (3 readings)					A021-600	2	 for CL switches:
					A021-620	2	
Single pole with 4 current transformers					A036-600	4	for A036: for A056:
		CL4	CL10		A056-600	4	
					A036-620	4	
		CL4	CL10		A056-620	4	
2 pole 2 current transformers					A037-600	3	
					A037-620	3	
					A037-621	3	
2 pole 3 current transformers					A019-600	5	
					A019-620	5	
					A038-600	5	
					A038-620	5	
					A038-621	5	
					A038-621	5	
2 pole 4 current transformers					A039-600	6	
					A039-620	6	

¹not available for switch types CL4 and CL10 ²available only up to switch type CA25B

Switch Function and Configuration

C, CA, CAD, CL Switches

Function	Escutch. Plate	Type/Handle				Code	Stages	Connection Diagram
		CA4 CA4-1 CAD4-1 CL4	CAD.. CA10- CA25 CL10	CA10B- CA25B	CA40- CA63			

Volt-ammeter Switches

3 phase - phase to phase 3 current						A027-600 A057-600	6	for A027:
						A028-600	7	
		3 phase voltage 3 phase current 4 wire						A033-600
3 phase voltage 3 phase current 3 wire						A035-600	5	for CL switches: *17 instead of 9

Control Switches

Stop switch						A174-600	1	
Start switch						A175-600	1	
Stop start switch single pole						A176-600	1	
Stop start switch 2 pole						A183-600	2	
Stop start switch with spring return from start to run						A178-600	1	
						A178-620	1	
Stop start switch with spring return to run for 2 units						A177-600	2	
						A177-620	2	

¹not available for switch types CL4 and CL10 ²available only up to switch type CA50

Function	Escutch. Plate	Type/Handle	Code	Stages	Connection Diagram	
		CA4 CA4-1 CAD4-1 CL4	CAD.. CA10- CA25 CL10	CA10B- CA25B	CA40 CA50	

Control Switches

Stop start switch with spring return to run with contactor interlock contactors for 2 units						A182-600	2	
						A182-620	2	
Motor voltage control switch						A150-600	2	

Control Switches with electrically isolated contacts

Stop start switch single pole						A789-600	1	
Stop start switch with spring return to 1						A791-600	1	
Stop start switch with spring return to run for 2 units						A790-600	2	
Contactor control with spring return to „OFF“						A179-600	2	
						A179-620	2	
Circuit breaker control						A537-600	2	

Control and Alarm Switches¹

With slip clutch and without indicator device						A190-600	5 ³	
Without indicator device						A192-600	2	

20 ¹Advise the indicator device, described in Catalog 101, page 7. ²not available for switch types CL10, CA25 and CA25B ³incl. slip clutch
⁴available only up to switch type CA40

Function	Escutch. Plate	Type/Handle				Code	Stages	Connection Diagram
		CA4 CA4-1 CAD4-1 CL4	CAD.. CA10- CA25 CL10	CA..B CA40- CA63	C80- C315			

Motor Reversing Switches

2 pole						A400-600	2	
						A400-620	2	
						A400-621	2	
3 pole						A401-600	3	
						A401-620	3	
						A401-621	3	
3 pole with spring return to „OFF“						A228-600	3	
						A228-620	3	
3 pole for use with reversing contactors						A402-600	4	

Motor Control Switches

2 speed 2 winding 0-A-BY or Δ						A451-600	3	
						A451-620	3	
3 speed 2 winding 0-AΔ-BY-AYY						A457-600	6	
						A457-620	6	

¹not available for switch type CA25 ²not available for switch types CA40-CA63 ³available only up to switch type CA50

Function	Escutch. Plate	Type/Handle				Code	Stages	Connection Diagram
		CA4 CA4-1 CAD4-1 CL4	CAD.. CA10- CA25 CL10	CA10B- CA25B	CA40- C315			

Motor Control Switches

2 speed single winding						A440-600	4	
						A440-620	4	
2 speed single winding without „OFF“						A466-600	4	
2 speed single winding with center „OFF“						A441-600	4	
						A441-620	4	
2 speed single winding reversing						A442-600	6	
						A442-620	6	
2 speed single winding for use with contactors						A444-600	5	
						A444-620	5	
2 speed reversing for 2 way operation with slip clutch for „OFF“ load use						A468-600	10 ¹	
						A468-620	10 ¹	

Function	Escutch. Plate	Type/Handle				Code	Stages	Connection Diagram
		CA4 CA4-1 CAD4-1 CL4	CAD.. CA10- CA25 CL10	CA..B CA40- CA63	C80- C315			



Star-delta Switches

OFF-star-delta						A410-600	4	
						A410-620	4	
Reversing						A413-600	5	
With auxiliary contact closed in „OFF“ position						A416-600	5	
For use with reversing contactors						A419-600	4	





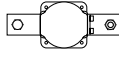





















Start and Run Switches

Split-phase start						A425-600	2	
						A425-620	2	
Split-phase start reversing						A426-600	3	
						A426-620	3	
Split-phase reversing auto cutout of start field winding						A622-600	3	

¹not available for switch types CL4 and CL10 ²not available for switch type CA25

Function/Type	Escutch. Plate	Handle	Code	Stages	Double Latching	Connection Diagram	L350 L630 L1000 L1250		L351 L631 L1001 L1251	
---------------	----------------	--------	------	--------	-----------------	--------------------	--------------------------------	-------------------------------------------------------------------------------------	--------------------------------	-------------------------------------------------------------------------------------

ON/OFF Switches with 60° Switching

1 pole 2 pole 3 pole 4 pole			A200-600 A201-600 A202-600 A203-600	1 2 3 4						
1 pole 2 pole 3 pole 4 pole			A200-620 A201-620 A202-620 A203-620	1 2 3 4						
1 pole 2 pole 3 pole 4 pole			A200-600 A201-600 A202-600 A203-600	2 2 4 4						
3 pole with lugs suitable for protective cover			A302-600	3						
1 pole 2 pole 3 pole 4 pole			A200-620 A201-620 A202-620 A203-620	2 2 4 4						
1 pole 2 pole 3 pole 4 pole			A200-600 A201-600 A202-600 A203-600	3 3 6 6						
1 pole 2 pole 3 pole 4 pole			A200-600 A201-600 A202-600 A203-600	2 4 6 8	● ●					
1 pole 2 pole 3 pole 4 pole			A200-600 A201-600 A202-600 A203-600	2 4 6 8						
1 pole 2 pole 3 pole 4 pole			A200-600 A201-600 A202-600 A203-600	3 6 9 12	● ● ●					
1 pole 2 pole 3 pole			A200-600 A201-600 A202-600	3 6 9						
1 pole 2 pole 3 pole			A200-600 A201-600 A202-600	4 8 12	● ●					
1 pole 2 pole 3 pole			A200-600 A201-600 A202-600	4 8 12						
1 pole 2 pole			A200-600 A201-600	5 10	●					

Function/Type	Escutch. Plate	Handle	Code	Stages	Double Latching	Connection Diagram	L350 L630 L1000 L1250	L351 L631 L1001 L1251
---------------	----------------	--------	------	--------	-----------------	--------------------	--------------------------------	--------------------------------

ON/OFF Switches with 90° Switching

1 pole 2 pole 3 pole 4 pole 1 pole preclose 60°			A290-600 A291-600 A292-600 A293-600	1 2 3 4				
1 pole 2 pole 3 pole 4 pole 1 pole preclose 60°			A290-600 A291-600 A292-600 A293-600	2 2 4 4				
3 pole with lugs suitable for protective cover			A307-600	3				
3 pole 360° rotation			A208-600	4				
1 pole 2 pole 3 pole 4 pole 1 pole preclose 60°			A290-600 A291-600 A292-600 A293-600	3 3 6 6				
1 pole 2 pole 3 pole 4 pole 1 pole preclose 60°			A290-600 A291-600 A292-600 A293-600	2 4 6 8				
1 pole 2 pole 3 pole 4 pole 1 pole preclose 60°			A290-600 A291-600 A292-600 A293-600	2 4 6 8	● ● ●			
1 pole 2 pole 3 pole 4 pole 1 pole preclose 60°			A290-600 A291-600 A292-600 A293-600	3 6 9 12	● ● ●			
1 pole 2 pole 3 pole			A290-600 A291-600 A292-600	3 6 9	● ● ●			1-3 pole
1 pole 2 pole 3 pole			A290-600 A291-600 A292-600	4 8 12	● ●			1-3 pole

● Additional length for switches size S2 for mounting E/EF = 27 mm
 ● Additional length for switches size S3 for mounting E/EF = 31,5 mm and mounting ER/VE = 20,1 mm

Function/Type	Escutch. Plate	Handle	Code	Stages	Double Latching	Connection Diagram	L350 L630 L1000 L1250	L351 L631 L1001 L1251
---------------	----------------	--------	------	--------	-----------------	--------------------	--------------------------------	--------------------------------

ON/OFF Switches with 90° Switching

1 pole 2 pole 3 pole	L1600			A290-600 A291-600 A292-600	4 8 12	● ● ●		1-3 pole
1 pole 2 pole	L2000			A290-600 A291-600	5 10	● ●		1- and 2 pole

Double-throw Switches without „OFF“ 60° Switching

1 pole 2 pole 3 pole 4 pole	L350/L351			A220-600 A221-600 A222-600 A223-600	2 4 6 8			1-4 pole
1 pole 2 pole 3 pole 4 pole	L400			A220-600 A221-600 A222-600 A223-600	2 4 6 8			1-4 pole
1 pole 2 pole 3 pole 4 pole	L600			A220-600 A221-600 A222-600 A223-600	3 6 9 12	● ●		1-4 pole
1 pole 2 pole 3 pole	L630/L631			A220-600 A221-600 A222-600	4 8 12	●		1-3 pole
1 pole 2 pole 3 pole	L800			A220-600 A221-600 A222-600	4 8 12	●		1-3 pole
1 pole 2 pole	L1000/L1001			A220-600 A221-600	6 12	●		1 and 2 pole
1 pole	L1200			A220-600	6			
1 pole	L1250/L1251			A220-600	8			
1 pole	L1600			A220-600	8			
1 pole	L2000			A220-600	10			

Function/Type	Escutch. Plate	Handle	Code	Stages	Double Latching	Connection Diagram	L350 L630 L1000 L1250	L351 L631 L1001 L1251
---------------	----------------	--------	------	--------	-----------------	--------------------	--------------------------------	--------------------------------

Double-throw Switches with Center „OFF“

1 pole 2 pole 3 pole 4 pole	L350/L351			A210-600 A211-600 A212-600 A213-600	2 4 6 8			1-4 pole
1 pole 2 pole 3 pole 4 pole	L400			A210-600 A211-600 A212-600 A213-600	2 4 6 8			1-4 pole
1 pole 2 pole 3 pole 4 pole	L600			A210-600 A211-600 A212-600 A213-600	3 6 9 12	● ●		1-4 pole
1 pole 2 pole 3 pole	L630/L631			A210-600 A211-600 A212-600	4 8 12	●		1-3 pole
1 pole 2 pole 3 pole	L800			A210-600 A211-600 A212-600	4 8 12	●		1-3 pole
1 pole 2 pole	L1000/L1001			A210-600 A211-600	6 12	●		1 and 2 pole
1 pole	L1200			A210-600	6			
1 pole	L1250/L1251			A210-600	8			
1 pole	L1600			A210-600	8			
1 pole	L2000			A210-600	10			

Multi-step Switches single pole without „OFF“

3 Step	L350/L351			A230-600	4			
3 Step	L400			A230-600	4			
4 Step	L350/L351			A231-600	4			
4 Step	L400			A231-600	4			
5 Step	L350/L351			A232-600	6			





- Additional length for switches size S2 for mounting E/EF = 27 mm
- Additional length for switches size S3 for mounting E/EF = 31,5 mm and mounting ER/VE = 20,1 mm

Function/Type	Escutch. Plate	Handle	Code	Stages	Double Latching	Connection Diagram	L350 L630 L1000 L1250	L351 L631 L1001 L1251
---------------	----------------	--------	------	--------	-----------------	--------------------	--------------------------------	--------------------------------

Multi-step Switches single pole without „OFF“

5 Step	L400			A232-600	6			
6 Step	L350/L351			A233-600	6			
6 Step	L400			A233-600	6			
7 Step	L350/L351			A234-600	8			
7 Step	L400			A234-600	8			
8 Step	L350/L351			A235-600	8			
8 Step	L400			A235-600	8			
9 Step	L350/L351			A236-600	10			
9 Step	L400			A236-600	10			
10 Step	L350/L351			A237-600	10			
10 Step	L400			A237-600	10			
11 Step	L350/L351			A238-600	12			
11 Step	L400			A238-600	12			
12 Step	L350/L351			A239-600	12			
12 Step	L400			A239-600	12			



Two Hole Panel Mounting or Mosaic Mounting	Terminals rotated 90°	Code	CA4 CA4-1 CAD4-1 CL4
--------------------------------------------	-----------------------	-------------	-------------------------------

	<p>Panel mounting</p> <p>Two hole panel mounting</p>	●	E E-V	● ●
	<p>Panel mounting with shaft seal Protection IP 66</p> <p>Two hole panel mounting</p>	●	EF EF-V	● ●
	<p>Panel mounting with round shaft for combining with commercial radio knobs</p> <p>Two hole panel mounting Shaft diam. 6 mm/.24 inch</p> <p>Two hole panel mounting Shaft diam. 6.35 mm/.25 inch</p>		E9 E91	● ●
	<p>Mosaic mounting</p> <p>For Siemens-Mosaic 30 mm grid depth</p> <p>For Subklew-, Kreutzenbeck-, Symo-Mosaic 28 mm 25 mm 25 mm grid depth</p> <p>For Mauell-Mosaic 30 mm grid depth</p>		E92 E93 E94	● ● ●









Mounting

C, CA, CAD, CL, L Switches







Two or Four Hole Panel Mounting	Terminals rotated 90°	Code	CAD.. CA10- CA25 CL10	CA10B- CA63	C80- C200-4 L350- L1251 Size S2	C315 L400- L2000 Size S3
----------------------------------------	-----------------------	-------------	--------------------------------	----------------	---------------------------------------------	-----------------------------------

 <p>Panel mounting</p> <p>Four hole panel mounting</p> <p>Four hole panel mounting Protection IP 66</p> <p>Two hole panel mounting Protection IP 65</p>	<p>●</p> <p>●</p> <p>●</p>	<p>E E-V</p> <p>EF EF-V</p> <p>E22 E22-V</p>	<p>●</p> <p>●</p> <p>●</p>	<p>●</p> <p>●</p> <p>●</p>	<p>●</p> <p>●</p> <p>●</p>	<p>●</p> <p>●</p> <p>●</p>
<p>Panel mounting using larger escutcheon plate and handle and with heavy duty latching</p>  <p>Four hole panel mounting</p> <p>Four hole panel mounting Protection IP 66</p>		<p>EG</p> <p>EGF</p>	<p>●</p> <p>●</p>	<p>CA40- CA63</p> <p>CA40- CA63</p>	<p>C80- C200-4</p> <p>C80- C200-4</p>	
<p>Panel and base mounting</p>  <p>Four hole mounting</p> <p>Four hole mounting Protection IP 66</p>		<p>ER</p> <p>ERF</p>	<p>●</p> <p>●</p>	<p>CAD.. CA10- CA25</p> <p>CAD.. CA10- CA25</p>	<p>●</p> <p>●</p>	<p>●</p> <p>●</p>



Two or Four Hole Panel Mounting	Code	CAD.. CA10- CA25 CL10	CA10B CA11B CA20B CA25B	CA40 CA50 CA63
---------------------------------	------	--------------------------------	----------------------------------	----------------------

	<p>Panel mounting with heavy duty latching and metal shaft</p> <p>Four screw panel mounting Mounting plate, escutcheon plate and handle of size S0</p>	KN2	●		
	<p>Four screw panel mounting Mounting plate, escutcheon plate and handle of size S1</p>	KN1	●	●	●
	<p>Four screw panel mounting Mounting plate, escutcheon plate and handle of size S1 and 6 mm square metal shaft</p>	KD1	●	●	●
	<p>Panel mounting with protective cover</p>	EC	CAD.. CA10- CA25	●	●
	<p>Four screw panel mounting with additional shaft seal Protection front IP 65 rear IP 30 for CA and CAD IP 42 for CA40-CA63</p>	ED	CAD.. CA10- CA25	●	●
	<p>Four screw panel mounting Protection front IP 40 rear IP 42</p>	EC1		●	
	<p>Four screw panel mounting with additional shaft seal Protection front IP 65 rear IP 42</p>	ED1		●	
	<p>Two screw panel mounting Protection front IP 65 rear IP 42</p>	ED22	CAD.. CA10- CA25		





Single Hole Mounting	Terminals rotated 90°	Code	CA4 CA4-1 CAD4-1 CL4	CAD.. CA10- CA25 CL10
----------------------	-----------------------	------	-------------------------------	--------------------------------

			Code	mm	mm
	With locking nut and shaft seal, protection IP 66	●	FS1	16/22	
	Without escutcheon plate		FS1-V	16/22	
		●	FT1		22
			FT1-V		22
		●	FT3		22/30
			FT3-V		22/30
	With square escutcheon plate	●	FS2	16/22	
			FS2-V	16/22	
		●	FT2		22
			FT2-V		22
		●	FT4		22/30
			FT4-V		22/30
	With size S1 square escutcheon plate and heavy duty latching	●	FH3		22
			FH3-V		22
	With rectangular escutcheon plate	●	FS4	16/22	
			FS4-V	16/22	
		●	FT6		22
			FT6-V		22
	With size S1 rectangular escutcheon plate and heavy duty latching	●	FH4		22
			FH4-V		22
	Mounting key for locking nut		S00 T170 09		



Base Mounting	Terminals rotated 90°	Code	CAD.. CA10- CA25 CL10	CA10B- CA63	C80- L2000
---------------	-----------------------	------	--------------------------------	----------------	---------------

<p>Base mounting</p>  <p>Base mounting - four hole</p> <p>For four hole base mounting and with integrated simplified door clutch, protection IP 65</p>	<p>●</p> <p>●</p>	<p>VE VE-V</p> <p>VF VF-V</p>	<p>CAD.. CA10- CA25</p> <p>CAD.. CA10- CA25</p>	<p>●</p> <p>●</p>	<p>●</p>
 <p>For two hole base mounting</p> <p>For two hole base mounting and with integrated simplified door clutch, protection IP 65</p>	<p>●</p> <p>●</p>	<p>VE22 VE22V</p> <p>VF22 VF22V</p>	<p>● CAD.. CA10- CA25</p> <p>● CAD.. CA10- CA25</p>		
 <p>Snap-on base mounting for track EN 60715</p>		<p>VE1</p>	<p>●</p>	<p>●</p>	

Base Mounting	Code	CA4 CA4-1 CAD4-1	CAD.. CA10- CA25 CL10
---------------	------	------------------------	--------------------------------

Base mounting				
	<p>Snap-on base mounting for track EN 60715 with escutcheon plate for 45 mm standard knock-out.</p>	VE2		●
	<p>Snap-on base mounting for track EN 60715. Both the escutcheon plate for 45 mm standard knock-out and the handle are adjustable in height.</p>	VE21 VE21V	●	CAD.. CA10- CA20 CA25
	<p>Snap-on base mounting for track EN 60715 with circular escutcheon plate for 46 mm knock-out.</p>	VE3		●
	<p>Base mounting - four hole - for circular escutcheon plate with 46 mm knock-out.</p>	VE4		CAD.. CA10- CA25

<p>Mounting Plates for Plaster Depth Boxes acc. to DIN 49070 and ÖNORM E6508</p>	<p>Code</p>	<p>CAD.. CA10- CA25</p>
----------------------------------------------------------------------------------	-------------	---------------------------------

	<p>Plaster depth trim</p>	<p>UE1</p>	<p>●</p>
	<p>With light</p> <p>With facility for light addition</p>	<p>UE2</p> <p>UE3</p>	<p>●</p> <p>●</p>
	<p>Plaster depth trim</p> <p>With light</p> <p>With facility for light addition</p>	<p>UE4</p> <p>UE5</p> <p>UE6</p>	<p>●</p> <p>●</p> <p>●</p>

Escutcheon Plates

60° switching

F070	F087	F088	F089	F133	F197	F198	F232	F243	F247	F263	F268	F310	F311	F323	F328	F352	F367
F379	F380	F470	F754	F072	F163	F164	F192	F193	F196	F230	F231	F234	F244	F257	F262	F264	F282
F288	F291	F313	F382	F441	F705	F721	F722	F750	F757	F758	F075	F076	F098	F220	F223	F356	F357
F377	F723	F071	F073	F080	F081	F085	F086	F090	F091	F092	F093	F094	F104	F194	F235	F237	F239
F240	F241	F249	F260	F269	F274	F281	F290	F292	F312	F314	F315	F316	F324	F331	F344	F354	F358
F359	F364	F370	F371	F373	F381	F385	F442	F444	F469	F732	F735	F759	F077	F100	F101	F102	F309
F342	F343	F361	F362	F363	F365	F366	F078	F191	F325	F326	F720	F074	F082	F096	F097	F195	F724
F256	F079	F083	F084	F095	F099	F185	F190	F199	F233	F236	F238	F242	F283	F725	F730	F731	F736
F737																	

90° switching

F056	F063	F068	F134	F201	F251	F252	F346	F456	F058	F065	F069	F177	F178	F182	F208	F253	F254
F340	F360	F378	F458	F443	F700	F743	F057	F061	F064	F067	F171	F181	F205	F207	F209	F320	F349
F437	F445	F715	F719	F059	F060	F062	F066	F170	F172	F173	F174	F175	F176	F179	F180	F186	F188
F202	F204	F206	F250	F265	F266	F286	F318	F327	F338	F339	F425	F716	F717	F718	F726	F733	F751
F755	F756																

Miscellaneous

F119	F130	F122	F126	F125	F129	F225	F248	F246	F261	F341	F345	F287	F123	F127	F145	F146	F148						
F706	F707	F245	F120	F124	F128	F131	F121	F132	F749									F990	F991	F801	F802	F803	F804
F805	F806	F807	F808	F809	F810	F811	F812	F813	F814	F815	F816	F817	F818	F819	F820	F821	F822						
F823	F824	F825	F826	F827	F828	F829	F830	F831	F832	F833	F834	F835	F837	F838	F839 ¹	F840 ²	F841 ³						

¹INTERRUPTEUR PRINCIPAL, OUVERTURE EN POSITION 0 ²INTERRUPTORE GENERALE, APRIRE SOLO CON MANIGLIA SU 0
³INTERRUPTOR PRINCIPAL, ABRIR ARMARIO SOLO EN POS. "0"

Handles

Type	Color	Code	Size				
			S00	S0	S1	S2	S3

Type	Color	Code	Size				
			S00	S0	S1	S2	S3

<p>R-Handle</p> 	black	G001	— ● ● ● ●
	red	G002	— ● ● ● ●
	white	G003	— ● ● ● ●
	electro-gray	G007	— ● ● ● ●

<p>I-Handle</p>  <p>S00 S0-S3</p>	black	G251	● ● ● ● ●
	red	G252	● ● ● ● ●
	white	G253	● ● ● ● ●
	electro-gray	G257	● ● ● ● ●

<p>F-Handle</p> 	black	G221	● ● ● ● —
	red	G222	● ● ● ● —
	white	G223	● ● ● ● —
	electro-gray	G227	● ● ● ● —

<p>B-Handle</p> 	black	G521	— ● ● — —
	red	G522	— ● ● — —
	white	G523	— ● ● — —
	electro-gray	G527	— ● ● — —

<p>S-Handle</p>  <p>S0 S1</p>	black	G301	— ● ● — —
	red	G302	— ● ● — —
	white	G303	— ● ● — —
	electro-gray	G307	— ● ● — —

<p>L-Handle</p> 	black	G501	— — ● — —
	red	G502	— — ● — —
	white	G503	— — ● — —
	electro-gray	G507	— — ● — —

















<p>P-Handle</p>  <p>S0 S1-S3</p>	black	G211	— ● ● ● ●
	red	G212	— ● ● ● ●
	white	G213	— ● ● ● ●
	electro-gray	G217	— ● ● ● ●

<p>K-Handle</p> 	black	G411	— — ● ● ●
	red	G412	— — ● ● ●
	white	G413	— — ● ● ●
	electro-gray	G417	— — ● ● ●

<p>Handwheel</p> 	black	G971	— — — — ●
------------------------------------------------------------------------------------------------------	-------	------	-----------

<p>O-Handle</p> 	black	G321	— — ● — —
	red	G322	— — ● — —
	white	G323	— — ● — —
	electro-gray	G327	— — ● — —

International Standards and Approvals

Country	Authority	Mark or Standard	CAD11/12	CA10	CA10B	CA40	L350/1	L1250/1	L400	L1200	
			CL4 CL10	CA4 CA4-1	CA11 CA20	CA11B CA20B	CA25 CA25B	CA50 CA63	C80 C125	L630/1 L1000/1	C315 C316
USA	Underwriters Laboratories Inc.	 ¹					●	●	●	●	
		 ² ₃	●	●	●	●	●		●		
Canada	UL investigated acc. to CSA	 ⁶	●	●	●	●	●	●	●	●	
		 ¹ c.						●	●	●	●
		 ² ₃ c.	●	●	●	●	●	●		●	
Switzerland	Schweizerischer Elektrotechnischer Verein		+	+	+	+	+	+	+	+	
Denmark	Danmarks Elektriske Materielkontrol		+	+	+	+	+	+	+	+	
Norway	Norges Elektriske Materielkontrol		+	+	+	+	+	+	+	+	
Sweden	Svenska Elektriska Materielkontrollanstalten		+	+	+	+	+	+	+	+	
Finland	Sähkötar-kastuskeskus		+	+	+	+	+	+	+	+	
Austria	Österreichischer Verband für Elektrotechnik		+	+	+	+	+	+	+	+	
Federal Republic of Germany	Verband Deutscher Elektrotechniker	VDE 0660 ⁴	+	+	+	+	+	+	+	+	
Great Britain	British Standards Institution	BS EN 60947 ⁴	+	+	+	+	+	+	+	+	
International Electrical Commission (IEC) Recommendation		IEC 60947 ⁵	+	+	+	+	+	+	+	+	
China	China Quality Certification Centre	 ⁷ GB14048.3		●	●						
Russian Federation	GOST	 ⁷ CH01	●	●	●	●		+	+	+	
Russian Federation	Russian Maritime Register of Shipping		●	●	●	●		●	+	+	
Germanischer Lloyd			+	+	+	+	+	+	+	+	
Lloyds Register EMEA			+	+	+	+	+	+	+	+	

● Switch approved + Switch conforms to requirements + No approval required

¹Approved under the "Component Program" (UL-Recognized Industrial Component). File No. E35541, Category Control No. NLRV2 (U.S.) resp. NLRV8 (Canada).

²Approved under the "Listing Program". File No. E35541, Category Control No. NLRV (U.S.) resp. NLRV7 (Canada).

³Switch types CAD11/CAD12 approved under the "Listing Program". File No. E60262, Category Control No. NRNT (U.S.) resp. NRNT7 (Canada).

⁴It is not required for Industrial Switchgear to bear a symbol but must conform to requirements. By stating the specific standard no. on the product the manufacturer declares that all requirements of the product standard are met.

⁵IEC does not operate an approval scheme.

⁶File No. 13002, Class No. 3211-05 resp. 4652-04.

⁷If this approval is required, please request when ordering.

Selection Data	CA4	CA10	CA11	CA20	CA25													
	CA4-1	CL4	CA10B	CL10	CA11B	CA20B	CA25B	CA40	CA50	CA63	C80	C125	C200-4	C315	C316			

Rated Insulation Voltage U_i	IEC 60947-3, EN 60947-3 ¹ VDE 0660 part 107 ¹	V	440	440	690	690	690	690	690	690	690	690	690	690	690	690	690	1000				
	SEV ⁴	V	380	380	660	690	660	660	690	690	690	690	660	660	–	660						
	UL/Canada	V	300	300	300	600	600	600	600	600	600	600	600	600	600	–	600					
	CEE/NEMKO	V	400/380	–	380	–	400	400	–	–	–	–	400	–	–	–						
	min. voltage	V																				
			on request																			
Rated Impulse Withstand Voltage U_{imp}		kV	4	4	6	6	6	6	6	6	6	6	6	6	6	6	6	8				
Rated Thermal Current I_U/I_{th}	IEC 60947-3, EN 60947-3 VDE 0660 part 107	A	10	10	20	20	20	25	32	40	50	63	115	150	200	315						
	SEV ⁴	A	10	10	16	16	16	25	32	40	50	63	100	160	–	315						
	380 V	A	–	–	12	12	12	25	32	40	50	63	–	–	–	315						
	660 V	A	–	–	12	12	12	25	32	40	50	63	–	–	–	315						
UL/Canada	A	10	10	20	20	20	30	30	45	55	65	100	150	–	240							
Rated Operational Current I_e																						
AC-21A	Switching of resistive loads, including moderate overloads	IEC 60947-3, EN 60947-3 VDE 0660 part 107	A	10	10	20	20	20	25	32	40	50	63	100	150	200	315					
AC-1	Resistive or low inductive loads	SEV ⁴	A	10	10	16	16	16	25	32	40	50	63	100	160	–	315					
		380 V	A	–	–	12	12	12	20	32	40	50	63	–	–	–	315					
		660 V	A	–	–	12	12	12	20	32	40	50	63	–	–	–	315					
AC-22A	Switching of combined resistive or low inductive loads including moderate overloads	IEC 60947-3, EN 60947-3 VDE 0660 220 V-500 V part 107 660 V-690 V	A	10	10	20	20	20	25	32	40	50	63	100	150	150	315					
			A	–	–	20	20	20	25	32	40	50	63	100	125	125	125					
AC-15	Switching of control devices, contactors, valves etc.	IEC 60947-3, EN 60947-3 VDE 0660 220 V-240 V part 107 380 V-440 V	A	2,5	2,5	5	5	5	8	12	14	16	16	–	–	–	–					
			A	1,5	1,5	4	4	4	5	6	6	7	7	–	–	–	–					
Pilot Duty		UL/Canada ⁴ Heavy		A300	C300	A300	A600	A600	A600	A300	A600	A600	A600	–	–	–	A600					
Ampere Rating	Resistive or low inductive loads	UL/Canada ⁴	A	10	10	20	20	20	30	30	45	55	60	100	150	–	240					
Resistive load/motor load		CEE	A	4/2	–	10/6	–	10/6	16/10	–	–	–	–	63/10	–	–	–					
		NEMKO	A	6/4 ²	–	10/6	–	–	20/10	–	–	–	–	–	–	–	–					
Breaking capacity	220 V-240 V	A	50	50	150	150	150	200	280	290	330	440	860	1100	1100	2000						
	380 V-440 V	A	50	50	150	150	150	200	250	290	330	440	860	1100	1100	2000						
	660 V-690 V	A	–	–	80	80	80	125	150	170	200	260	400	490	490	340						
Power loss per contact at I_U		W	0,4/0,9	0,4	0,9	1	0,9	0,9	0,7	1	1,8	2,8	5,8	3,8	6,7	17						
Resistance to vibration			min. 4 g, 2-100 Hz, 1,6 mm																			
Resistance to shock			min. 5 g, 6 ms																			
Short Circuit Protection	Max. fuse size	(gL/gG-characteristic)	A	10	10	25	25	25	35	35	50	63	63	125	200	200	315					
	Rated short-time withstand current	(1s-current)	A	60	90	140	140	140	280	480	950	950	950	1300	2000	2000	4200					
DC Switching Capacity⁶	No. of series contacts	1	2	3	4	5	6	8	Rated Operational Current I_e													
		Voltage V								CA4	CA10	CA11	CA20	CA25							C315 ³	
	Resistive loads	$T \leq 1$ ms	24	48	70	95	120	145	190	CA4-1	CL4	CA10B	CL10	CA11B	CA20B	CA25B	C26S	C32S	C42S	C80	C125	C316 ³
			48	95	140	190	240	290	350	10	10	20	20	20	25	32	–	50	–	115	–	315
			60	120	180	240	300	360	450	6	6	12	12	12	20	25	32	40	63	100	150	250
			110	220	330	440	550	660	–	2,5	2,5	4,5	4,5	4,5	7,5	10	23	27	30	–	–	–
			220	440	660	–	–	–	–	0,7	0,7	1	1	1	1,5	2	6,5	–	–	–	–	–
		440	660	–	–	–	–	–	0,3	0,3	0,4	0,4	0,4	0,5	0,6	1,2	–	–	–	–	–	
	Inductive loads	$T = 50$ ms	24	48	70	95	120	145	190	0,2	0,2	0,27	0,27	0,27	0,3	0,3	0,4	–	–	–	–	–
			30	60	90	120	150	180	240	6	6	12	12	12	20	25	32	40	63	100	150	250
		48	95	140	190	240	290	350	3	3	5	5	5	9	12	25	30	55	33	50	70	
		60	120	180	240	300	360	450	1	1	2	2	2	3	3	16	20	–	–	–	–	
		110	220	330	440	550	660	–	0,7	0,7	1	1	1	1,5	1,5	11	15	–	–	–	–	
								0,3	0,3	0,4	0,4	0,4	0,5	0,5	3,2	3,5	–	–	–	–		
Ambient Temperature of Stages^{5,7}	open at 100 % I_U/I_{th}		55 °C during 24 hours with peaks up to 60 °C																			
	enclosed at 100 % I_{the}		35 °C during 24 hours with peaks up to 40 °C																			

¹Valid for lines with grounded common neutral termination, overvoltage category III, pollution degree 3. Values for other supply systems on request. ²Valid for CA4 only. ³DC switching capacity applies to ON/OFF switches. Switching capacity for other configurations on request. ⁴International Standards and Approvals, refer to page 39. ⁵For electromagnetic optional extras see additional data in Catalog 101. ⁶Values for switches with spring return on request. ⁷Storage temperature: -40 °C to 85 °C (in case of temperature below -5 °C no shock load permissible).

Selection Data	CA4	CA10	CA11	CA20	CA25											C315
	CA4-1	CL4	CA10B	CL10	CA11B	CA20B	CA25B	CA40	CA50	CA63	C80	C125	C200-4	C316		

Rated Utilization Category		IEC 60947-3, EN 60947-3 VDE 0660 part 107																
AC-2	Slip ring motor starting, reversing and plugging, star-delta starting CA4-CA50	3 phase	220 V-240 V	kW	2,5	2,5	4	4	4	5,5	7,5	10	11	18,5	30	37	37	55
		3 pole	380 V-440 V		4,5	4,5	7,5	7,5	7,5	11	15	18,5	22	30	45	55	55	90
			500 V		-	-	10	10	10	15	18,5	22	30	40	55	75	75	110
			660 V-690 V		-	-	10	10	10	13	15	22	30	37	55	55	55	55
AC-3	Direct-on-line starting, star-delta starting CA63-C315	3 phase	220 V-240 V	kW	1,5	1,5	3	3	3	4	5,5	7,5	11	11	15	22	22	37
		3 pole	380 V-440 V		2,2	2,2	5,5	5,5	5,5	7,5	11	15	18,5	18,5	30	37	37	55
			500 V		-	-	5,5	5,5	5,5	7,5	11	15	18,5	18,5	30	37	37	55
			660 V-690 V		-	-	5,5	5,5	5,5	7,5	11	15	18,5	22	30	30	30	37
AC-4	Direct-on-line starting, reversing, plugging and inching	1 phase	110 V-120 V	kW	0,3	0,3	0,6	0,6	0,6	1,5	2,2	2,5	3	3	3,7	5,5	5,5	11
		2 pole	220 V-240 V		0,55	0,55	2,2	2,2	2,2	3	4	5,5	6	6	7,5	11	11	22
			380 V-440 V		0,75	0,75	3	3	3	3,7	5,5	7,5	11	11	13	18,5	18,5	30
		3 phase	220 V-240 V		0,37	0,37	0,55	0,55	0,55	1,5	2,5	3,7	4	5,5	6	10	10	15
		3 pole	380 V-440 V		0,55	0,55	1,5	1,5	1,5	3	5,5	6	7	7,5	11	15	15	25
			500 V		-	-	1,5	1,5	1,5	3	5,5	6	7	7,5	11	15	15	25
			660 V-690 V		-	-	1,5	1,5	1,5	3	5,5	6	7,5	9	11	15	15	22
AC-23A	Frequent switching of motors or other high inductive loads	1 phase	110 V-120 V	kW	0,15	0,15	0,3	0,3	0,3	0,45	0,75	1,1	1,2	1,2	1,5	2,2	2,2	4
		2 pole	220 V-240 V		0,25	0,25	0,75	0,75	0,75	1,1	1,5	2,2	2,4	2,4	3	4	4	7,5
			380 V-440 V		0,5	0,5	1,5	1,5	1,5	2,2	3	3,7	4	4	5,5	7,5	7,5	11
		3 phase	220 V-240 V		1,8	1,8	3,7	3,7	3,7	5,5	7,5	7,5	11	15	30	37	37	75
		3 pole	380 V-440 V		3	3	7,5	7,5	7,5	11	15	18,5	22	30	45	75	75	132
			500 V		-	-	7,5	7,5	7,5	11	15	18,5	22	30	55	90	90	132
			660 V-690 V		-	-	7,5	7,5	7,5	11	15	18,5	22	30	45	55	55	37
AC-23A	Frequent switching of motors or other high inductive loads	1 phase	110 V-120 V	kW	0,37	0,37	0,75	0,75	0,75	1,5	2,2	2,2	2,5	4	5,5	11	11	18,5
		2 pole	220 V-240 V		0,75	0,75	2,5	2,5	2,5	3	4	4	5,5	10	15	22	22	37
			380 V-440 V		1,1	1,1	3,7	3,7	3,7	5,5	7,5	7,5	11	18,5	22	37	37	55
		3 phase	220 V-240 V		1,8	1,8	3,7	3,7	3,7	5,5	7,5	7,5	11	15	30	37	37	75
		3 pole	380 V-440 V		3	3	7,5	7,5	7,5	11	15	18,5	22	30	45	75	75	132
			500 V		-	-	7,5	7,5	7,5	11	15	18,5	22	30	55	90	90	132
			660 V-690 V		-	-	7,5	7,5	7,5	11	15	18,5	22	30	45	55	55	37
Ratings	UL/Canada	Standard motor load DOL-Rating (similar AC-3)	110 V-120 V	HP	0,75	0,75	1,5	1,5	1,5	3	5	7,5	7,5	7,5	10	15	-	30
			220 V-240 V		1	1	3	3	3	7,5	10	15	15	15	20	25	-	75
			440 V-480 V		-	-	-	5	5	10	-	25	25	30	30	40	-	75
			550 V-600 V		-	-	-	5	5	10	-	25	30	30	40	50	-	60
		1 phase	110 V-120 V	HP	0,33	0,33	0,5	0,5	0,5	1,5	2	3	3	3	5	7,5	-	15
			220 V-240 V		0,75	0,75	1	1	1	3	5	7,5	7,5	7,5	10	15	-	40
			277 V		0,75	0,75	2	2	2	3	5	7,5	7,5	10	10	15	-	40
			440 V-480 V		-	-	-	2	2	5	-	15	15	15	20	25	-	50
		2 pole	440 V-480 V	HP	-	-	-	2	2	5	-	15	20	20	25	30	-	50
			550 V-600 V		-	-	-	2	2	5	-	15	20	20	25	30	-	50
			110 V-120 V		-	-	0,5	-	0,5	1	2	-	-	-	7,5	10	-	15
			220 V-240 V		-	-	1	-	1	2	3	-	-	-	15	20	-	30
Heavy motor load Reversing-Rating (similar AC-4)	440 V-600 V	HP	-	-	-	3	5	-	-	-	-	25	30	-	40			
	110 V-120 V		-	-	0,17	-	0,17	0,33	1,5	-	-	-	3	5	-	7,5		
	220 V-240 V		-	-	0,5	-	0,5	0,75	3	-	-	-	7,5	10	-	15		
	277 V		-	-	0,6	-	0,6	1	3	-	-	-	7,5	10	-	15		
Max. Permissible Wire Gage - Use copper wire only Single-core or stranded wire		mm ²	2x	AWG	1,5	1x ²	2x	1x ²	2x	2x	2x							
			1,5		0,5-1,52,5	0,5-2,52,5	4	6	16	16	16	35	70	95 ¹	185 ¹			
			14		20-16	12	20-14	12	10	8	6	6	6	2	2/0	-	MCM	
																	350	
Flexible wire (sleeving in accordance with DIN 46228) Flexible AWG wires (without sleeve)		mm ²	2x	AWG	1,5	1x ²	2x	1x ²	2x	2x	2x							
			1,5		0,5-1,52,5	0,5-2,52,5	4	4	10	10	10	25	50	95 ¹	150 ¹			
			(1)		(-)	(2,5)	(-)	(2,5)	(2,5)	(4)	(10)	(10)	(10)	(25)	(50)	-	MCM	
			16		20-16	14	20-14	14	12	10	6	6	6	3	1/0	-	300	
Connecting wire - outside diameter	mm	-	1,5-2,8	-	1,5-3,6	-	-	-	-	-	-	-	-	-	-	-	-	
		-	8,5	-	11,5	-	-	-	-	-	-	-	-	-	-	-	-	
		-	5-40	-	5-40	-	-	-	-	-	-	-	-	-	-	-	-	
Connecting wire - plug-in depth	mm	-	8,5	-	11,5	-	-	-	-	-	-	-	-	-	-	-		
Permissible connecting ambiente temperature range	°C	-	5-40	-	5-40	-	-	-	-	-	-	-	-	-	-	-		

¹Cable lug must accept M8 (C200-4) and M12 (C315/C316) screw. ²The insulation material of the conductor has to be PVC (typical wire codes are H05V-K0,5 ... H07V-K1,5 or H05V-U0,5 ... H07V-U1,5 etc.). Other materials on request. Connected conductors, which have to be disconnected and re-connected again must be cut in order to ensure a proper electrical connection and to prevent a complete cut-off of the wire insulation.

Selection Data	L350	L630			L1000			L1250		
	L351 L400 L600	L631 L800	L1001 L1200	L1251 L1600	L2000					

Rated Insulation Voltage U_i	IEC 60947-3, EN 60947-3 ¹ VDE 0660 part 107 ¹ UL/Canada ²	V	690	690	690	690	690	690	690	690	690	690		
		V	600	600	600	600	600	600	600	600	600	600		
	min. voltage	V	on request											
Rated Impulse Withstand Voltage U_{imp}		kV	6	6	6	6	6	6	6	6	6	6		
Rated Thermal Current I_U/I_{th}	IEC 60947-3, EN 60947-3 VDE 0660 part 107													
	Ambient temp. +35 °C during 24 hours with peaks up to +40 °C	A	350	500	800	630	1100	1000	1450	1250	1900	2400		
	Ambient temp. +55 °C during 24 hours with peaks up to +60 °C	A	350	500	750	600	950	920	1300	1100	1700	2000		
	UL/Canada ²	A	350	400	630	630	800	1000	1200	1250	1600	2000		
Rated Operational Current I_e	AC-20A No-load operation	IEC 60947-3, EN 60947-3 VDE 0660 part 107	690 V	A	350	500	800	630	1100	1000	1450	1250	1900	2400
	Occasional switching under load $\cos \varphi$ 0,8 (AC-20B)	3 phase, 3 pole and 1 phase, 2 pole	220 V-440 V	A	350	500	800	500	1000	630	1200	630	1200	1200
			500 V	A	350	450	500	450	630	500	800	500	800	800
			660 V-690 V	A	315	350	400	360	400	400	400	400	400	400
	AC-21B Switching of resistive loads, including moderate overloads	3 phase, 3 pole and 1 phase, 2 pole	220 V-440 V	A	250	450	500	350	630	400	800	400	800	800
			500 V	A	250	400	450	315	500	350	630	350	630	630
			660 V-690 V	A	200	300	350	250	350	300	350	300	350	350
	Interrupting Rating	UL/Canada ² CSA	600 V	A	200	300	300	200	300	200	300	200	200	200
			600 V	A	200	200	200	200	200	200	200	200	200	200
	Rated Utilization Category	IEC 60947-3, EN 60947-3 VDE 0660 part 107												
AC-23B Occasional switching of motors or other high inductive loads		3 phase 3 pole	220 V-240 V	kW	45	75	75	45	75	45	75	45	75	75
			380 V-440 V	kW	90	132	132	90	132	90	132	90	132	132
			500 V	kW	110	132	132	110	132	110	132	110	132	132
			660 V-690 V	kW	55	55	65	65	65	65	65	65	65	65
Short Circuit Protection		(aR-characteristic) (1s-current)	Max. fuse size	A	400	500	800	630	1100	1000	2x800	1250	2x1000	2x1250
			Rated short-time withstand current	A	on request									
Terminals	for connection screw	Cable lug or copper bus												
			M12	M12	M16	M16	M16	M16	M16	M16	2xM16	4xM16		
		length	mm	20	30	40	30	40	40	40	40	50	50	50
Ambient Temperature of Stages^{3,4}	55 °C during 24 hours with peaks up to 60 °C, permissible load see Rated Thermal Current.													

¹Valid for lines with grounded common neutral termination, overvoltage category III, pollution degree 3. Values for other supply systems on request.
²International Standards and Approvals, refer to page 39. ³For electromagnetic optional extras see additional data in Catalog 101. ⁴Storage temperature: -40 °C to 85 °C (in case of temperature below -5 °C no shock load permissible).

Selection Data	CAD4-1	CAD11	CAD12
-----------------------	--------	-------	-------

Rated Insulation Voltage U_i	IEC 60947-3, EN 60947-3 ¹ VDE 0660 part 107 SEV ² North America	V V V	440 – 300	600 600 300	600 600 300
	min. voltage	V	1 ⁷	1	6
Rated Impulse Withstand Voltage U_{imp}			on request		
Rated Thermal Current I_{th}	IEC 60947-3, EN 60947-3 VDE 0660 part 107 SEV ² North America	A A A	5 – 5	6 5 6	6 5 6
Rated Operational Current I_e	IEC 60947-3, EN 60947-3 VDE 0660 part 107 North America ³				
AC-21A	Switching of resistive loads, including moderate overloads	1 V/6 V 12 V/24 V 48 V/110 V 220 V/400 V 440 V/500 V 600 V	A A A A A A	5/2 1,2/0,7 0,45/0,25 0,15/– 0,1/– –	6/3 2/1 0,8/0,4 0,2/0,13 0,1/0,08 0,05
AC-1	Resistive or low inductive loads	SEV ² 1 V/6 V 12 V/24 V 48 V/110 V 220 V/380 V 440 V/500 V 600 V	A A A A A A	– – – – – –	5/3 2/1 0,8/0,4 0,2/0,13 0,1/0,08 0,05
Power loss per contact at I_u		W	0,4	0,5	0,2
Short Circuit Protection					
	Max. fuse size (gL-characteristic)	A	5	6	6
	Rated short-time withstand current (1s-current)	A	30	35	50
DC Switching Capacity⁵	IEC 60947-3, EN 60947-3 VDE 0660 part 107 SEV ² North America ³				
DC-1	Resistive load T = 1 ms	1 V/6 V 12 V/24 V 48 V/60 V 110 V/220 V 240 V/500 V 600 V	A A A A A A	3/1,2 0,7/0,4 0,25/0,2 0,13/– 0,08/– –	4/2,5 1,5/0,8 0,3/0,27 0,2/0,1 0,08/0,03 0,02
Max. Permissible Wire Gage - Use copper wire only					
	Single-core or stranded wire	mm ² AWG	2x 1,5 14	2x 2,5 12	2x 2,5 12
	Flexible wire (sleeving in accordance with DIN 46228) Flexible AWG wires (without sleeve)	mm ² AWG	2x 1,5 (1) 16	2x 2,5 (2,5) 14	2x 2,5 (2,5) 14
Ambient Temperature of Stages^{4,6}	open at 100 % I_u/I_{th} enclosed at 100 % I_{the}		55 °C during 24 hours with peaks up to 60 °C 35 °C during 24 hours with peaks up to 40 °C		

¹Valid for lines with grounded common neutral termination, overvoltage category III, pollution degree 3. Values for other supply systems on request.
²International Standards and Approvals, refer to page 39. ³Max. 300 V. ⁴For electromagnetic optional extras see additional data in Catalog 101.
⁵Values for switches with spring return on request. ⁶Storage temperature: -40 °C to 85 °C (in case of temperature below -5 °C no shock load permissible).
⁷Values with lower voltages on request.

Two or Four Hole Panel Mounting

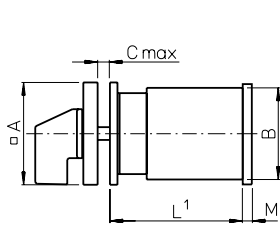

E
for CA4, CA4-1,
CAD4-1
E-V
for CL4
E-V
for CA4, CA4-1,
CAD4-1
E
for CL4

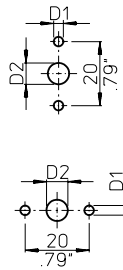

E
E-V
ER

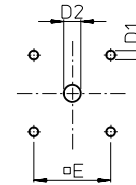

	CA4 CA4-1 CAD4-1	CA10 CA11 CAD11	CA10B CA11B CA20B	CA40 ³ CA50 ³ CA63 ³	C80	C125 C200-4	L switches Size S2	L switches Size S3
A	30 1.18	48 1.89	48 1.89	48 (64) 1.89 (2.52)	64 2.52	64 (88) 2.52 (3.46)	88 3.46	88 3.46
B	29,5 1.16	38x46 1.50x1.81	43 1.69	50x56 1.97x2.20	45 1.77	46 1.81	56 2.20	56 2.20
C	4 .16	4 .16	4 .16	4 .16	4 .16	4 .16	5,5 .22	5,5 .22
D1	3,2 .13	3,2 .13	5 .20	5 .20	5 .20	5 .20	5 (6) .24	6 .24
D2	8-11 .31-.43	8-11 .31-.43	8-15 .31-.59	8-15 .31-.59	8-15 .31-.59	8-15 .31-.59	10-15 .39-.59	10-15 .39-.59
E	-	-	36 1.42	36 1.42	36 1.42	36 (48) 1.42 (1.89)	48 1.89	48 1.89
M²	-	-	4,5 .18	-	4,5 .18	5,5 .22	5 .20	5,5 .22

²M, additional length for mounting ER only
³Dimensions in () for ER mounting plate only

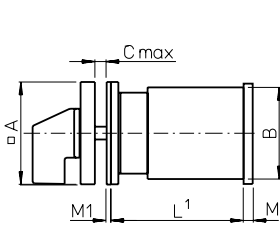

EF
for CA4, CA4-1,
CAD4-1
EF-V
for CL4
EF-V
for CA4, CA4-1,
CAD4-1
EF
for CL4

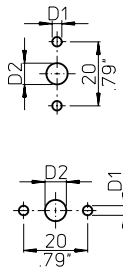

EF
EF-V
ERF

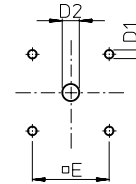

	CA4 CA4-1 CAD4-1	CA10 CA11 CAD11	CA10B CA11B CA20B	CA40 ³ CA50 ³ CA63 ³	C80	C125 C200-4	L switches Size S2	L switches Size S3
A	30 1.18	48 1.89	48 1.89	48 (64) 1.89 (2.52)	64 2.52	64 (88) 2.52 (3.46)	88 3.46	88 3.46
B	29,5 1.16	38x46 1.50x1.81	43 1.69	50x56 1.97x2.20	45 1.77	46 1.81	56 2.20	56 2.20
C	4 .16	4 .16	4 .16	4 .16	4 .16	4 .16	5,5 .22	5,5 .22
D1	3,2 .13	3,2 .13	5 .20	5 .20	5 .20	5 .20	5 (6) .24	6 .24
D2	8-11 .31-.43	8-11 .31-.43	15-19 .59-.75	15-19 .59-.75	15-19 .59-.75	15-19 .59-.75	19-22 .75-.87	19-22 .75-.87
E	-	-	36 1.42	36 1.42	36 1.42	36 (48) 1.42 (1.89)	48 1.89	48 1.89
M²	-	-	4,5 .18	-	4,5 .18	5,5 .22	5 .20	5,5 .22
M1	1 .04	1 .04	-	-	-	-	-	-

²M, additional length for mounting ERF only
³Dimensions in () for ERF mounting plate only

Two or Four Hole Panel Mounting

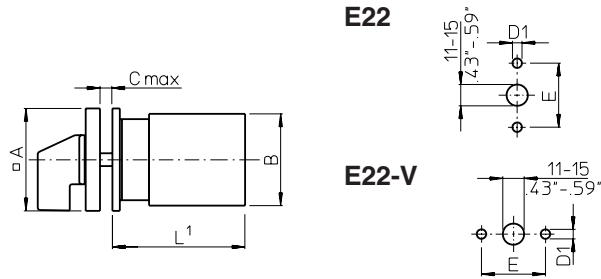

	CA10	CA11	CAD11	CAD12	CL10	CA20	CA25
A	48 1.89	48 1.89	48 1.89	48 1.89	48 1.89	48 1.89	48 1.89
B	43 1.69	50x56 1.97x2.20	45 1.77	46 1.81	45 1.77	46 1.81	46 1.81
C	4 .16	4 .16	4 .16	4 .16	4 .16	4 .16	4 .16
D1	5 .20	5 .20	5 .20	5 .20	5 .20	5 .20	5 .20
E	30 1.17	30 1.17	30 1.17	30 1.17	30 1.17	30 1.17	30 1.17

**EG
EGF**

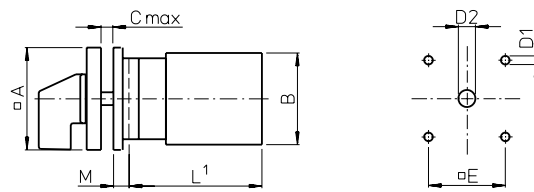

	CA10	CA11	CAD11	CAD12	CL10	CA20	CA25	CA40	CA50	C80	C125	C200-4
											L switches	Size S2
A	64 2.52	64 2.52	64 2.52	64 2.52	64 2.52	64 2.52	64 2.52	88 3.46	130 5.12	130 5.12	130 5.12	130 5.12
B	43 1.69	50x56 1.97x2.20	45 1.77	46 1.81	45 1.77	46 1.81	46 1.81	55,5x64 2.19x2.52	84 3.30	84 3.30	84 3.30	88 3.46
C	4 .16	4 .16	4 .16	4 .16	4 .16	4 .16	4 .16	5,5 .22	7 .28	7 .28	7 .28	7 .28
D1	5 .20	5 .20	5 .20	5 .20	5 .20	5 .20	5 .20	6 .24	7 .28	7 .28	7 .28	7 .28
D2	10-15 .39-.59	10-15 .39-.59	10-15 .39-.59	10-15 .39-.59	10-15 .39-.59	10-15 .39-.59	10-15 .39-.59	13-17 .51-.67	15,5-20 .61-.79	15,5-20 .61-.79	15,5-20 .61-.79	15,5-20 .61-.79
E	48 1.89	48 1.89	48 1.89	48 1.89	48 1.89	48 1.89	48 1.89	68 2.68	104 4.09	104 4.09	104 4.09	104 4.09
M	6,7 .26	6,7 .26	6,7 .26	6,7 .26	6,7 .26	6,7 .26	6,7 .26	0,5 .02	2 .08	2 .08	2 .08	2 .08

¹see page 51

Four Hole Panel Mounting or Mosaic Mounting

E9
E91

E92

	CA4	
	CA4	
	CAD4-1	CL4
B	29,5	38x46
	1.16	1.50x1.81

E93
E94

	CA4				
	CA4-1				
	CAD4-1				
CL4	E9	E91	E92	E93	E94
D	6	6,35	-	-	-
	.24	.25	-	-	-
F	12	12,8	-	-	-
	.47	.50	-	-	-
G	15,4	17,4	32,5	28,5	32,5
	.61	.69	1.28	1.12	1.28
K	4,7	5,5	-	-	-
	.19	.22	-	-	-
M	-	-	-	4	-
	-	-	-	.16	-

KN1
KD1
KN2

KN2	CA10			
	CA11			
	CAD11			
	CAD12	CL10	CA20	CA25
A	48	48	48	48
	1.89	1.89	1.89	1.89
B	43	50x56	45	46
	1.69	1.97x2.20	1.77	1.81
C	4	4	4	4
	.16	.16	.16	.16
D1	5	5	5	5
	.20	.20	.20	.20
D2	8-15	8-15	8-15	8-15
	.31-.59	.31-.59	.31-.59	.31-.59
E	36	36	36	36
	1.42	1.42	1.42	1.42
M	5,2	5,2	5,2	5,2
	.20	.20	.20	.20

KN1	CA10					
	CA11					
	CAD11					
	CAD12	CL10	CA20	CA25	CA10B	CA40
					CA11B	CA50
					CA20B	CA25B
						CA63
A	64	64	64	64	64	64
	2.52	2.52	2.52	2.52	2.52	2.52
B	43	50x56	45	46	56	56
	1.69	1.97x2.20	1.77	1.81	2.20	2.20
C	4	4	4	4	4	4
	.16	.16	.16	.16	.16	.16
D1	5	5	5	5	5	5
	.20	.20	.20	.20	.20	.20
D2	10-15	10-15	10-15	10-15	10-15	10-15
	.39-.59	.39-.59	.39-.59	.39-.59	.39-.59	.39-.59
E	48	48	48	48	48	48
	1.89	1.89	1.89	1.89	1.89	1.89
M	4,7	4,7	4,7	4,7	7	7
	.19	.19	.19	.19	.28	.28

Two or Four Hole Panel Mounting

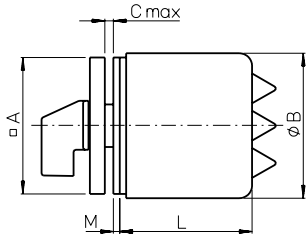

ED22

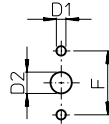

**EC
ED
EC1
ED1**

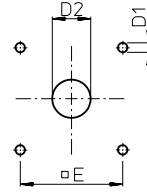

		CA10 CAD11 CAD12		CA11		CA20		CA25		CA10B		CA11B		CA20B CA25B		CA40 CA50 CA63	
		EC		EC		EC		EC		EC		EC1		EC		EC	
		ED		ED22		ED		ED22		ED		ED		ED		ED	
A		48	48	48	48	64	48	64	48	64	64	64	64	64	64	64	88
		1.89	1.89	1.89	1.89	2.52	1.89	2.52	1.89	2.52	2.52	2.52	2.52	2.52	2.52	2.52	3.46
B		50	74	50	74	68	74	68	74	88	74	88	74	88	74	108	
		1.97	2.91	1.97	2.91	2.68	2.91	2.68	2.91	3.46	2.91	3.46	2.91	3.46	2.91	4.25	
EC/EC1	C	4	-	4	-	4	-	4	-	4	4	4	4	4	4	4	5.5
		.16	-	.16	-	.16	-	.16	-	.16	.16	.16	.16	.16	.16	.16	.22
ED/ED1/ ED22	C	2	4	2	4	2	4	2	4	2	4	4	4	4	4	4	7.5
		.08	.16	.08	.16	.08	.16	.08	.16	.08	.16	.16	.16	.16	.16	.16	.30
D1		5	5	5	5	5	5	5	5	5	5	5	5	5	5	5	6
		.20	.20	.20	.20	.20	.20	.20	.20	.20	.20	.20	.20	.20	.20	.20	.24
EC/EC1	D2	8-15	-	8-15	-	8-15	-	8-15	-	10-15	10-15	10-15	10-15	10-15	10-15	10-15	13-15
		.31-.59	-	.31-.59	-	.31-.59	-	.31-.59	-	.39-.59	.39-.59	.39-.59	.39-.59	.39-.59	.39-.59	.39-.59	.51-.59
ED/ED1/ ED22	D2	18-22	11-15	18-22	11-15	18-22	11-15	18-22	11-15	22-25	19-22	22-25	19-22	22-25	19-22	28-33	
		.71-.87	.43-.59	.71-.87	.43-.59	.71-.87	.43-.59	.71-.87	.43-.59	.87-.98	.75-.87	.87-.98	.75-.87	.87-.98	.75-.87	1.10-1.30	
E		36	-	36	-	48	-	48	-	48	48	48	48	48	48	48	68
		1.42	-	1.42	-	1.89	-	1.89	-	1.89	1.89	1.89	1.89	1.89	1.89	1.89	2.68
F		-	30	-	30	-	30	-	30	-	-	-	-	-	-	-	-
		-	1.17	-	1.17	-	1.17	-	1.17	-	-	-	-	-	-	-	-
ED/ED22	M	2	1.5	2	1.5	2	1.5	2	1.5	2	-	2	-	2	-	2.2	
		.08	.06	.08	.06	.08	.06	.08	.06	.08	-	.08	-	.08	-	.09	
Stages L	1	53,5	74,3	53,5	74,3	-	74,3	-	74,3	-	73,7	-	73,7	-	73,7	101	
		2.10	2.93	2.10	2.93	-	2.93	-	2.93	-	2.90	-	2.90	-	2.90	3.98	
	2	53,5	74,3	53,5	74,3	-	74,3	-	74,3	-	73,7	-	73,7	-	73,7	101	
		2.10	2.93	2.10	2.93	-	2.93	-	2.93	-	2.90	-	2.90	-	2.90	3.98	
	3	67,5	74,3	67,5	94,3	-	74,3	-	94,3	-	73,7	-	93,7	-	93,7	101	
		2.66	2.93	2.66	3.71	-	2.93	-	3.71	-	2.90	-	3.69	-	3.69	3.98	
	4	67,5	74,3	81,5	94,3	-	94,3	-	94,3	-	93,7	-	93,7	-	93,7	101	
		2.66	2.93	3.21	3.71	-	3.71	-	3.71	-	3.69	-	3.69	-	3.69	3.98	
	5	81,5	94,3	-	-	103	-	103	-	-	93,7	103	-	103	-	139	
		3.21	3.71	-	-	4.06	-	4.06	-	-	3.69	4.06	-	4.06	-	5.47	
	6	81,5	94,3	-	-	-	-	-	-	103	-	127	-	127	-	139	
		3.21	3.71	-	-	-	-	-	-	4.06	-	5	-	5	-	5.47	
7	-	-	-	-	-	-	-	-	127	-	139,5	-	139,5	-	139		
	-	-	-	-	-	-	-	-	5	-	5.47	-	5.47	-	5.47		
8	-	-	-	-	-	-	-	-	127	-	152	-	152	-	177		
	-	-	-	-	-	-	-	-	5	-	5.98	-	5.98	-	6.97		
9	-	-	-	-	-	-	-	-	139,5	-	164,5	-	164,5	-	177		
	-	-	-	-	-	-	-	-	5.47	-	6.48	-	6.48	-	6.97		
10	-	-	-	-	-	-	-	-	152	-	177	-	177	-	177		
	-	-	-	-	-	-	-	-	5.98	-	6.97	-	6.97	-	6.97		
11	-	-	-	-	-	-	-	-	152	-	-	-	-	-	215		
	-	-	-	-	-	-	-	-	5.98	-	-	-	-	-	8.46		
12	-	-	-	-	-	-	-	-	164,5	-	-	-	-	-	215		
	-	-	-	-	-	-	-	-	6.48	-	-	-	-	-	8.46		

Single Hole Mounting or Base Mounting

FS1...
FT1...
FT3...

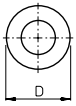

FS1...
FS2...
FS4...

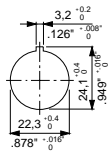
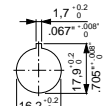

FH3...
FS2...
FT2...
FT4...

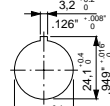

FH4...
FS4...
FT6...

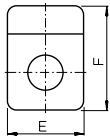

FT3...
FT4...

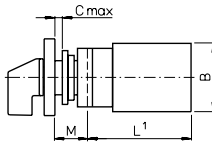
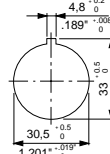
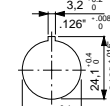

A/E

FH3...

FH4...

B

C

D

F

M

FH4...

FH3...

FH4...

CA4 CA4-1	CL4	CA10 CA11 CAD11	CL10	CA20	CA25
30	30	48	48	48	48
1.18	1.18	1.89	1.89	1.89	1.89
-	-	64	64	64	64
-	-	2.52	2.52	2.52	2.52
-	-	64	64	64	64
-	-	2.52	2.52	2.52	2.52
28	38x46	43	50x56	45	46
1.10	1.50x1.81	1.69	1.97x2.20	1.77	1.81
5	5	6	6	6	6
.20	.20	.24	.24	.24	.24
29.5	29.5	39	39	39	39
1.16	1.16	1.54	1.54	1.54	1.54
39	39	59	59	59	59
1.54	1.54	2.32	2.32	2.32	2.32
-	-	78.5	78.5	78.5	78.5
-	-	3.09	3.09	3.09	3.09
12.5	12.5	18.2	18.2	18.2	18.2
.49	.49	.72	.72	.72	.72
-	-	25.2	25.2	25.2	25.2
-	-	.99	.99	.99	.99
-	-	25.2	25.2	25.2	25.2
-	-	.99	.99	.99	.99

VE
VE-V

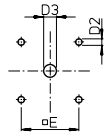
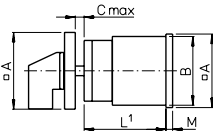
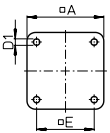

VF
VF-V

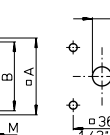
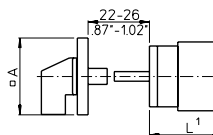
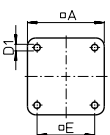

VE22
VE22V

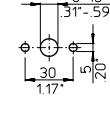
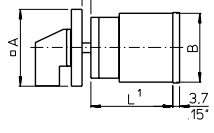
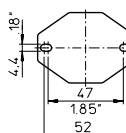

VF22
VF22V

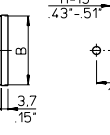
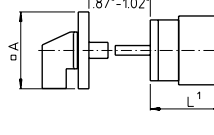
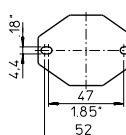

	CA10 CA11 CAD11 CAD12	CL10	CA20	CA25 ²	CA10B CA11B CA20B	CA25B	CA40 ² CA50 ² CA63 ²	C80	C125 C200-4	L switches Size S2	L switches Size S3
A	48 1.89	48 1.89	48 1.89	48 (64) 1.89 (2.52)	64 2.52	64 2.52	64 (88) 2.52 (3.46)	88 3.46	88 3.46	88 3.46	128 5.04
B	43 1.69	50x56 1.97x2.20	45 1.77	46 1.81	56 2.20	56 2.20	55.5x64 2.19x2.52	84 3.30	88 3.46	88 3.46	126 4.96
C	10.5 .41	10.5 .41	10.5 .41	10.5 .41	13.5 .53	13.5 .53	13.5 .53	16 .63	16 .63	16 .63	19.3 .76
D1	4.1 .16	-	4.1 .16	4.1 .16	4.1 .16	4.1 .16	5.4 .21	5.4 .21	5.4 .21	5.4 .21	7 .28
D2	5 .20	-	5 .20	5 .20	5 .20	5 .20	5 (6) .20 (.24)	6 .24	6 .24	6 .24	7 .28
D3	8-15 .31-.59	-	8-15 .31-.59	8-15 .31-.59	10-15 .39-.59	10-15 .39-.59	10-15 .39-.59	13-17 .51-.67	13-17 .51-.67	13-17 .51-.67	15.5-20 .61-.79
E	36 1.42	-	36 1.42	36 (48) 1.42 (1.89)	48 1.89	48 1.89	48 (68) 1.89 (2.68)	68 2.68	68 2.68	68 2.68	104 4.09
M	2.2 .09	-	2.2 .09	3.2 .13	2.5 .10	2.5 .10	5.1 .21	8.9 .35	8.9 .35	27 1.06	11.4 .45

²Dimensions in () for revertive mounting plate

Base Mounting

VE1

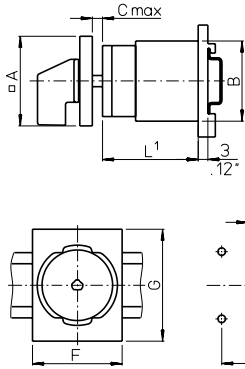

VE2

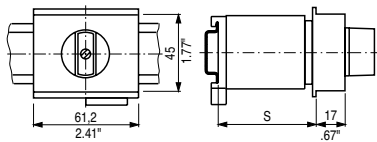

VE3

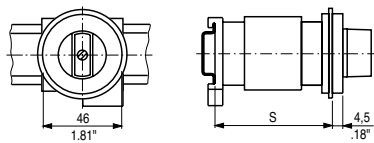

VE4

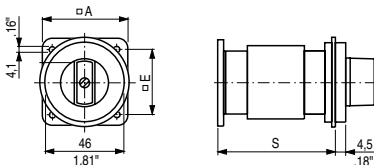

	CA10	CA11	CAD11	CAD12	CL10	CA20	CA25	CA10B	CA11B	CA20B	CA25B	CA40	CA50	CA63
A	48	48	48	48	48	48	48	64	64	64	64	64	64	64
	1.89	1.89	1.89	1.89	1.89	1.89	1.89	2.52	2.52	2.52	2.52	2.52	2.52	2.52
B	43	50x56	45	46	46	56	56	55,5x64	55,5x64	55,5x64	55,5x64	55,5x64	55,5x64	55,5x64
	1.69	1.97x2.20	1.77	1.81	1.81	2.20	2.20	2.19x2.52	2.19x2.52	2.19x2.52	2.19x2.52	2.19x2.52	2.19x2.52	2.19x2.52
C	10,5	10,5	10,5	10,5	10,5	13,5	13,5	13,5	13,5	13,5	13,5	13,5	13,5	13,5
	.41	.41	.41	.41	.41	.53	.53	.53	.53	.53	.53	.53	.53	.53
D1	5	5	5	5	5	5	5	5	5	5	5	5	5	5
	.20	.20	.20	.20	.20	.20	.20	.20	.20	.20	.20	.20	.20	.20
D2	8-15	8-15	8-15	8-15	8-15	10-15	10-15	10-15	10-15	10-15	10-15	10-15	10-15	10-15
	.31-.59	.31-.59	.31-.59	.31-.59	.31-.59	.39-.59	.39-.59	.39-.59	.39-.59	.39-.59	.39-.59	.39-.59	.39-.59	.39-.59
E	36	36	36	36	36	48	48	48	48	48	48	48	48	48
	1.42	1.42	1.42	1.42	1.42	1.89	1.89	1.89	1.89	1.89	1.89	1.89	1.89	1.89
F	48	48	48	48	48	70	70	70	70	70	70	70	70	70
	1.89	1.89	1.89	1.89	1.89	2.76	2.76	2.76	2.76	2.76	2.76	2.76	2.76	2.76
G	60	60	60	60	60	60	60	60	60	60	60	60	60	60
	2.36	2.36	2.36	2.36	2.36	2.36	2.36	2.36	2.36	2.36	2.36	2.36	2.36	2.36

VE21 (for CA4, CA4-1 and CAD4-1)

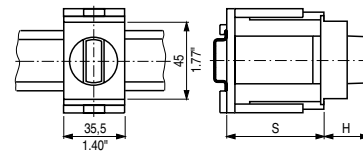

VE21 (for CA10-CA20)

VE21V (for CA25)

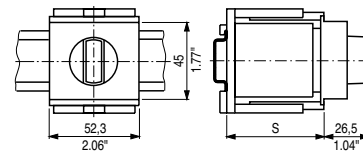

	VE2			VE3		VE4			VE21, VE21V				
	CA10 CAD11 CAD12	CA11 CA20 CL10	CA25	CA10 CAD11 CAD12	CA11 CA20 CL10	CA10 CAD11 CAD12	CA11 CA20 CA25	CA25	CA4 CA4-1 CAD4-1	CA10 CAD11	CA11 CA20	CA20	CA25
	Max. no. of stages			Max. no. of stages		Max. no. of stages			No. of stages				
S = 46 1.81	3	1	-	1	1	1	2	-	1/2	1/2	1/2	1/2	1
S = 50 1.97	3	1	1	2	1	2	2	1	3	3	-	-	2
S = 61 2.40	4	2	2	3	2	3	3	2	4	-	-	-	-
S = 67 2.64	5	2	2	3	2	3	3	2	-	-	3	3	-
S = 69 2.70	5	3 ²	3	4	3	4	4	3	-	-	-	-	3
									5	-	-	-	-
									-	4/5	-	-	-
									-	-	4	-	-
									6	-	-	4	-
									-	6	-	-	4

¹see page 51 ²not available for switch type CA20

Wall Mounting, Escutcheon Plates and Additional Length

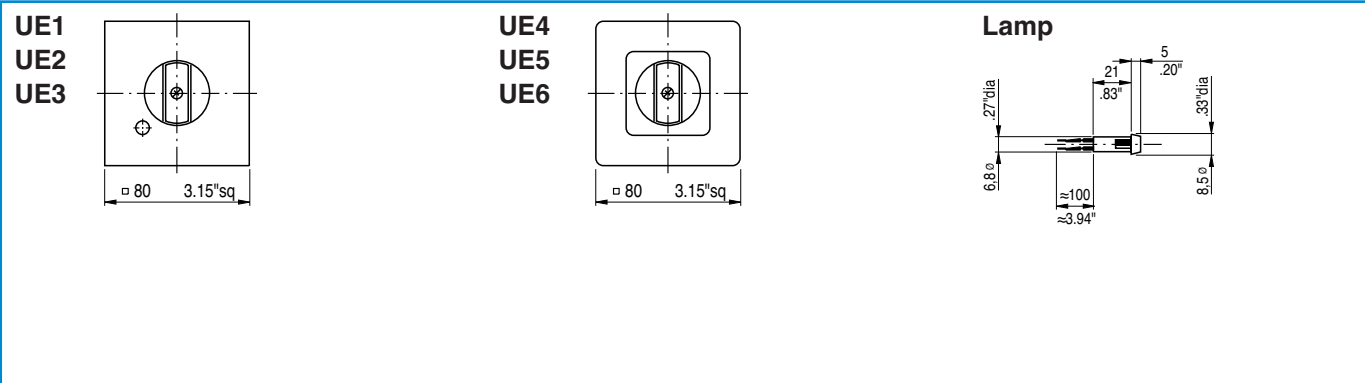

Escutcheon plates for mounting E, EF, ER, ERF, EG, EGF, KN1, KD1, KN2, EC, EC1, ED, ED1, VE, VE1, VF

Size	A	C
S00	30 1.18	5,5 .22
S0	48 1.89	6,3 .25
S1	64 2.52	7,4 .29
S2	88 3.46	8,5 .33
S3	130 5.12	11,5 .45

Size	A	B	C
S00	30 1.18	39 1.54	5,5 .22
S0	48 1.89	59 2.32	6,7 .26
S1	64 2.52	78 3.07	7,4 .29

Additional length for amendment (page 4)

	CA10	CA11	CA40
CAD11	CA20	CA50	
CAD12	CA25	CA63	
S0 switches with latching mechanism size S1	5,4 .21	-	-
S1 switches with latching mechanism size S2	-	-	8,2 .32
with snap action	-	14,3 .56	in preparation

Quick connects for switches CA4-4

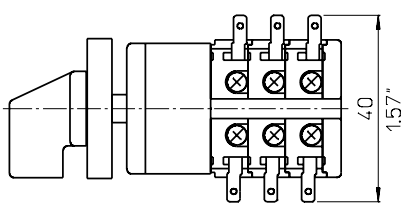

Dimensions mm
inch

Additional Length

Terminal lugs for switches C200-4-, C315, C316 and L switches

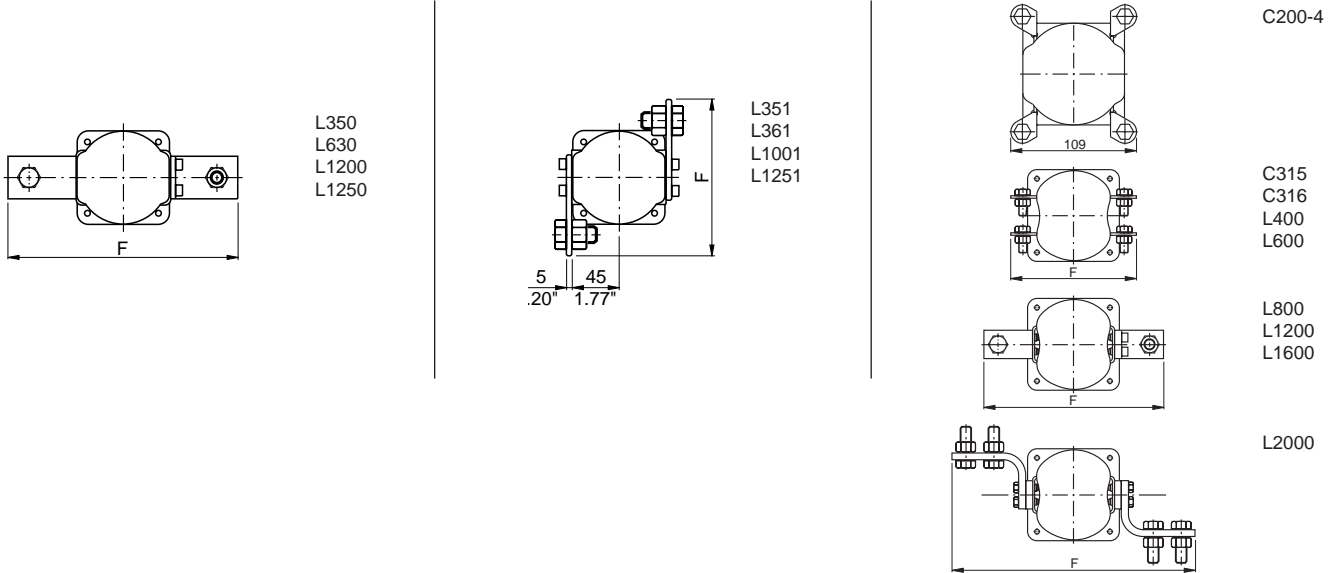

	L350	L630	L1000	L1250	L351	L631	L1001	L1251	C315 C316	L400	L600	L800 L1200	L1600 L2000
F	190	220	230	240	138	148	148	148	150	180	208	256	326
	7.48	8.66	9.06	9.45	5.43	5.83	5.83	5.83	5.91	7.09	8.19	10.08	12.83

Length L

Stages	CA4		CA10		CA40								C125		C315	
	CA4-1	CL4	CAD11	CL10	CA11	CA20	CA25	CA10B	CA11B	CA20B	CA25B	CA63	C80	L switches Size S2	L switches Size S3	
1	30	34	33,5	37,2	36,7	37,7	39	38,9	42,1	43,1	44,4	42,5	61,5	67,5	78,6	
	1.18	1.34	1.32	1.46	1.44	1.48	1.51	1.53	1.66	1.70	1.75	1.67	2.42	2.66	3.09	
2	38	46	43	49,9	49,4	50,4	53	48,4	54,8	55,8	58,4	55,2	88,0	100	117,2	
	1.50	1.81	1.69	1.96	1.94	1.98	2.09	1.91	2.16	2.20	2.30	2.17	3.46	3.94	4.61	
3	46	58	52,5	62,6	62,1	63,1	67	57,9	67,5	68,5	72,4	67,9	114,5	132,5	155,8	
	1.81	2.28	2.07	2.46	2.44	2.48	2.64	2.28	2.66	2.70	2.85	2.67	4.51	5.22	6.13	
4	54	70	62	75,3	74,8	75,8	81	67,4	80,2	81,2	86,4	80,6	141	165	194,4	
	2.13	2.76	2.44	2.96	2.94	2.98	3.19	2.65	3.16	3.20	3.40	3.17	5.55	6.50	7.65	
5	62	82	71,5	88	87,5	88,5	95	76,9	92,9	93,9	100,4	93,3	167,5	197,5	233	
	2.44	3.23	2.81	3.46	3.44	3.48	3.74	3.03	3.66	3.70	3.95	3.67	6.59	7.78	9.17	
6	70	94	81	100,7	100,2	101,2	109	86,4	105,6	106,6	114,4	106	194	230	271,6	
	2.76	3.70	3.19	3.96	3.94	3.98	4.29	3.40	4.16	4.20	4.50	4.17	7.64	9.06	10.69	
7	78	106	90,5	113,4	112,9	113,9	123	95,9	118,3	119,3	128,4	118,7	220,5	262,5	310,2	
	3.07	4.17	3.56	4.46	4.44	4.48	4.84	3.78	4.66	4.70	5.05	4.67	8.68	10.33	12.21	
8	86	118	100	126,1	125,6	126,6	137	105,4	131	132	142,4	131,4	247	295	348,8	
	3.39	4.65	3.94	4.96	4.94	4.98	5.39	4.15	5.16	5.20	5.60	5.17	9.72	11.61	13.73	
9	94	-	109,5	138,8	138,3	139,3	151	114,9	143,7	144,7	156,4	144,1	273,5	327,5	387,4	
	3.70	-	4.31	5.46	5.44	5.48	5.94	4.52	5.66	5.70	6.15	5.67	10.77	12.89	15.25	
10	-	-	119	151,5	151	152	165	124,4	156,4	157,4	170,4	156,8	300	360	426	
	-	-	4.68	5.96	5.94	5.98	6.50	4.90	6.16	6.20	6.70	6.17	11.81	14.17	16.77	
11	-	-	128,5	-	163,7	164,7	179	133,9	169,1	170,1	184,4	169,5	326,5	392,5	464,6	
	-	-	5.06	-	6.44	6.48	7.05	5.27	6.66	6.70	7.25	6.67	12.85	15.45	18.29	
12	-	-	138	-	176,4	177,4	193	143,4	181,8	182,8	198,4	182,2	353	425	503,2	
	-	-	5.43	-	6.94	6.98	7.60	5.65	7.16	7.20	7.80	7.17	13.90	16.73	19.81	

The Range of “Blue Line” Switchgear

Technical literature covering the following products is available on request.

	Catalog Number
Main Switches and Main Switches with Emergency Function 16 A-315 A Maintenance Switches 20 A-315 A Switch Disconnectors 20 A-315 A According to IEC 60947-3, EN 60947-3, VDE 0660 part 107, IEC 60204, EN 60204 and VDE 0113	500
CL Switches 10 A-20 A C, CA and CAD Switches 10 A-315 A and L Switches 350 A-2400 A C, CA and CAD switches are designed for universal application. They are recommended for instrument, isolator, double-throw and motor control. L switches are designed for load and off-load applications. They are used to switch resistive or low inductive loads.	100
Optional Extras and Enclosures The complete product line, a large number of optional extras is available, including door interlocks, push-pull devices, cylinder and padlock attachments, control and indicator devices, AC motor drives, as well as enclosures, both insulated and metal.	101
A and AD Switches 6 A-25 A A and AD switches have 4 contacts in each switching stage. These switches provide an extensive range of switch functions and require a minimum mounting depth. Up to 24 switching positions are possible, with availability of 48 contacts per 12 stage switch column.	110
CG, CH and CHR Switches 10 A-25 A Ultra compact CG, CH and CHR switches are ideally suited for control and instrumentation applications. Switch terminals are “finger-proof” and conveniently accessible for wiring and are delivered open. All CG4 switches offer specially designed gold plated contacts or H-bridges with “cross-wire” contact systems, which facilitates their use in electronic circuitry and chemically aggressive environments.	120
DH, DHR, DK and DKR Switches 6 A-16 A DH, DHR, DK and DKR switches incorporate unique corrosion resistant contacts that permit operation on system voltage as low as 1 V. They have fully enclosed and protected contacts which can be operated either by rotary and/or lateral handle movement. D switches are used in calibration and semiconductor circuits. They are also used for relay and contactor control.	130
X Switches 200 A-630 A X switches can be applied for load, tap and gang switching duties. They incorporate 6 contacts in each switching stage. Their compact design provides a minimum length dimension for mounting purposes.	140
KG Switches 20 A-315 A and KH and KHR Switches 16 A-80 A KG, KH and KHR switches are excellent circuit interruptors. They have high through fault and fault making capacities and are especially designed for use as isolators and safety switches for machine tools, distribution panels and switchboards. KG ON/OFF switches offer unusually high dimensioned air and creepage distances between terminals which are designed for time saving “straight-line” wiring. ON/OFF switches are available with up to 8 poles and double-throw switches are available with up to 4 poles.	150
Contactors 16 A-115 A and Motor Starters 1,1 kW-55 kW These include control relays, motor contactors, two and four pole output contactors, heating contactors, thermal overload relays.	200
Push Buttons and Pilot Lights, 22,5 mm Ø A complete range of state-of-the-art push buttons and pilot lights represent an ideal combination of functional security and economical efficiency in a modular design.	302

SALES AND SERVICE ORGANIZATION

Australia

Kraus & Naimer Pty. Ltd.
379 Liverpool Road, ASHFIELD, N.S.W. 2131
Tel: +61 2 9797-7333, Fax: 0092
salesaus@krausnaimer.com

Austria

Kraus & Naimer GmbH
Schumanngasse 35, Postfach 431
A-1181 WIEN
Tel: +43 1 404 06-0, Fax: 404 06-190
aso@krausnaimer.com

Belgium, Luxembourg

Kraus & Naimer B.V.
Ikaros Business Park
Ikaroslaan 2
B-1930 ZAVENTHEM
Tel: +32 2 757-0141, Fax: 1640
sales.be@krausnaimer.com

Brazil

Central and South America
Kraus & Naimer Ind. Com. Ltda.
Rua Santa Monica, 1061
Parque Industrial San Jose
06715-865 Cotia - SP
Tel: +55 11 2198-1288, Fax: 1251
knbrasil@krausnaimer.com.br

Canada

Kraus & Naimer Ltd.
219 Connie Crescent, Unit: 13A
CONCORD, Ontario, L4K 1L4
Tel: +1 905 738-1666, Fax: 9327
salescan@krausnaimer.com

Cyprus

ELECTROMATIC CONSTRUCTIONS LTD.
72, Evagoras Pallikarides Str., CY-2235 LATSIA-Nicosia
P. O. Box 12630, CY-2251 LATSIA-Nicosia
Tel: +357 2 48 41 41, Fax: 48 57 47

Czech Republic

OBZOR, výrobní družstvo Zlín
Na Slanici 378
CZ-76413 ZLÍN
Tel: +420 57 7195-111/-153 (Techn. Supp.)
Fax: +420 57 7195-152/-138
ots@obzor.cz

Denmark

THIIM A/S
Transformervej 31
DK-2730 HERLEV
Tel: +45 4485 8000, Fax: 8005
thiim@thiim.com

Finland

Kraus & Naimer Oy
Karitie 7
FIN-01530 VANTAA
Tel: +358 9 825-424-0, Fax: 424-10
myynti@krausnaimer.com

France

Kraus & Naimer s.a.s.
33, rue Bobillot
F-75013 PARIS
Tél: +33 1 58 40 80 80, Fax: 45 80 91 19
ventes@krausnaimer.com

Germany

Kraus & Naimer GmbH
Wikingerstraße 20-28, D-76189 KARLSRUHE
Postfach 10 01 24, D-76231 KARLSRUHE
Tel: +49 721 59 88-0, Fax: 59 28 28
sales.ger@krausnaimer.com

Great Britain

Kraus & Naimer Ltd.
115 London Road
NEWBURY/BERKSHIRE RG14 2AH
Tel: +44 1635 262626, Fax: 37807
sales-uk@krausnaimer.com

Greece

KALAMARAKIS-SAPOUNAS S. A.
Ionias & Neromilou Str., P. O. Box 46566
GR-13671 ACHARNES/ATHENS
Tel: +30 2 10 240-6000-6, Fax: 240-6007
kalamarakis.sapounas@ksa.gr

Hungary

GANZ, Schalter- u. Gerätefabrik
X. Kőbányal út 41/c, Postfach 87
H-1475 BUDAPEST
Tel: +36 1 261-5479, Fax: 4685
ganzkk@ganzkk.hu

Iceland

BRAEDURNIR ORMSSON EHF
Lágmúli 6-8, P. O. Box 8670
REYKJAVIK
Tel: +354 530-28 00, Fax: 28 10
skuli@ormsson.is

India

Liaison Office, **Kraus & Naimer Pte. Ltd.**
10B, 1st Floor, Infinity,
Ashar Commercial Complex, Gladly Alwares Road
Off Pokhran Road no. 2,
THANE (W) 400 610
Tel: +91 22 66716451, Fax: 66716451
india@krausnaimer.com

Republic of Ireland

Kraus & Naimer Ltd.
Bay 145, Shannon Free Zone
SHANNON, Co. Clare
Tel: +353 61 704700, Fax: 471084
sales-ie@krausnaimer.com

Italy

Kraus & Naimer s.r.l.
Via Terracini, 9
I-24047 TREVIGLIO (BG)
Tel: +39 0363-30 11 12, Fax: 30 21 13
sales-ita@krausnaimer.com

Japan

Kraus & Naimer Ltd.
Yoshiwada Building 2F
1-11-6 Hamamatsucho
Minato-Ku, TOKYO 105-0013
Tel: +81 3 3436-6151, Fax: 6325
sales-jpn@krausnaimer.com

Mexico

JC Ingeniería y Control, SA de CV
Ángel Gaviño 30,
C. Satélite, C. Medicos,
Naucalpan Edo. de Mexico, C.P. 53100
Tel. (+52 55) 55 62 75 77, Fax. 55 62 04 34
ventas@jcingenieriacontrol.com

Middle East - UAE

Branch Office, **Kraus & Naimer Pte. Ltd.**
SAIF Zone, P. O. Box 121607,
Sharjah, UAE
Tel: +971 6 557 8886
Fax: +971 6 557 8088
uae@krausnaimer.com

Netherlands

Kraus & Naimer B.V.
Wegtersweg 38-40, Postbus 199
NL-7556 BR HENGEL0 (Ov.)
Tel: +31 74 291-9441, Fax: 8380
sales.nl@krausnaimer.com

New Zealand

Kraus & Naimer Ltd.
42 Miramar Avenue, WELLINGTON 6022
P. O. Box 15-009, WELLINGTON 6243
Tel: +64 4 380-9888, Fax: 9877
sales-nz@krausnaimer.com

Norway

Kraus & Naimer AS
Hjalmar Brantings vei 8, P. O. Box 21, Økern
N-0508 OSLO
Tel: +47 22 64 44 20, Fax: 65 39 49
ordre.no@krausnaimer.com

Poland

ASTAT sp. z o.o.
ul. Dąbrowskiego 461
PL-60451 POZNAN
Tel: +48 61 848-8871/72, Fax: 8276
info@astat.com.pl

Portugal

ELECTRICOL-DAMAS, FERREIRA & DAMASCENO, LDA.
Apartado 1063, S. Ant. Cavaleiros
P-2670 LOURES
Tel: +351 21 989-8939, Fax: 988-6464
Im.emertex@electricol.pt

Singapore

Kraus & Naimer Pte. Ltd.
Blk 115A, Commonwealth Drive
#03-17/23
SINGAPORE 149 596
Tel: +65 6473-8166, Fax: 8643
sgp@krausnaimer.com

Slovenia

SCHRACK Technik d.o.o.
Pameče 175
SI-2380 Slovenj Gradec
Tel: +386 2 883 92 00, Fax: +386 2 884 34 71
m.abeln@schrack.si

Republic of South Africa

Kraus & Naimer Pty. Ltd.
7 Village Crescent, Linbro Village
Linbro Business Park, SANDTON 2065
P. O. Box 511, KELVIN 2054
Tel: +27 11 608-6060, Fax: 608-2874
salesZAF@krausnaimer.com

Spain

HAZEMEYER HES. S.L.
Pol. Ind. Gaserans
Sector 3, Parcela 7B
17451 SANT FELIU DE BUIXALLEU (GIRONA)
Tel: +34 972 87-4450, Fax: 87-4402
hazemeyer@grupo-hes.net

Sweden

Kraus & Naimer AB
Dr. Widerströms Gata 11, FRUÅNGEN
Box 42097, S-126 14 STOCKHOLM
Tel: +46 8 97 00 80, Fax: 97 87 33
order.se@krausnaimer.com

Switzerland

AWAG Elektrotechnik AG
Sandbühlstraße 2, Postfach
CH-8604 VOLKETSCHWIL
Tel: +41 44 908 19 19, Fax: 19 99
info@awag.ch, www.awag.ch

Turkey

KARDEŞ ELEKTRİK SANAYİ VE TİCARET ANONİM ŞİRKETİ
Beşyol, Eski Londra Asfaltı-6
TR-34295 İSTANBUL-Sefaköy
Tel: +90 212 624-9204, Fax: 592-4810
info@unalkardes.com.tr

USA

Kraus & Naimer Inc.
760 New Brunswick Road
SOMERSET, NJ 08873
Tel: +1 732 560-1240, Fax: 8823
salesusa@krausnaimer.com



Kraus & Naimer

BLUE LINE switchgear



YOUR SALES CONTACT



Kraus & Naimer Produktion GmbH

A-1181 Wien · Schumanngasse 31-39 · PF 0046
Telefon: +43 1 404 06 · Telefax: +43 1 404 06 255
knw@krausnaimer.com · www.krausnaimer.com
124765 d · UID-Nr. ATU 14707101